



Incremental encoders
DKV60 measuring wheel encoder

DKV60-A2K00100



Model Name > [DKV60-A2K00100](#)
Part No. > [1036267](#)

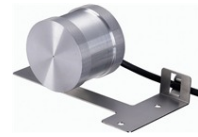

Illustration may differ

At a glance

- Complete, preassembled measuring system
- Measuring wheel with knurl or O-ring for adaptation to the measuring surface
- Mounting bracket made from anti-corrosive spring steel
- High resolution up to 0.1 mm (1 ... 2.000 pulses/revolution)
- Electrical interfaces: Open collector NPN, TTL/RS-422 or HTL/push pull.
- Connection via cable outlet, for radial or axial use with open ends or fitted with an M12 connector

Your benefits

- Complete system with universal mounting clamps and integrated cable guidance enables simple and quick mounting
- Spring steel mounting clamps allow high level of measuring accuracy when deflecting the measuring wheel in X and Y directions
- Low-cost encoder with outstanding performance
- Withstands harsh environments due to a high IP protection class, a non-corrosive mounting bracket and a rugged housing
- Compact dimensions enable simple installation even where space is cramped



Performance

Initialization time:	40 s
Error limits 'O' ring surface:	± 4 mm
Resolution:	2 mm
Smallest measuring step:	0.5 mm
Pulses per revolution:	100 ¹⁾

¹⁾ Pulses per 200 mm

Mechanical data

Mechanical interface:	Measuring drum, O ring surface
Mass:	0.42 kg
Maximum operating speed:	1,500 U/min
Bearing lifetime:	2 x 10 ⁹ revolutions

Electrical data

Electrical interface:	4.5 V ... 5.5 V, TTL/RS422, Cable, 1.5 m
Connection type:	Cable, 1.5 m
Supply voltage:	4.5 V ... 5.5 V

Output current:	30
Reference signal, number:	1
Reference signal, position:	90 °, electronically, gated with A and B
MTTFd: mean time to dangerous failure:	600 a (EN ISO 13849-1) ¹⁾

¹⁾ This product is a standard product and does not constitute a safety component as defined in the Machinery Directive.

Calculation based on nominal load of components, average ambient temperature 40°C, frequency of use 8760 h/a. All

electronic failures are considered hazardous. For more information, see document no. 8015532.

Ambient data

EMC:	EN 61000-6-2, EN 61000-6-3
Protection class standard:	IEC 60529
Air humidity:	90 % ¹⁾
Working temperature range:	-10 °C ... 60 °C
Storage temperature range:	-40 °C ... 70 °C, without package
Resistance to shocks:	50 g, 7 ms (EN 60068-2-27)
Resistance to vibration:	20 g, 10 Hz ... 2,000 Hz (EN 60068-2-6)
Enclosure rating:	IP 65

¹⁾ Condensation of the optical scanning not permitted

Dimensional drawing

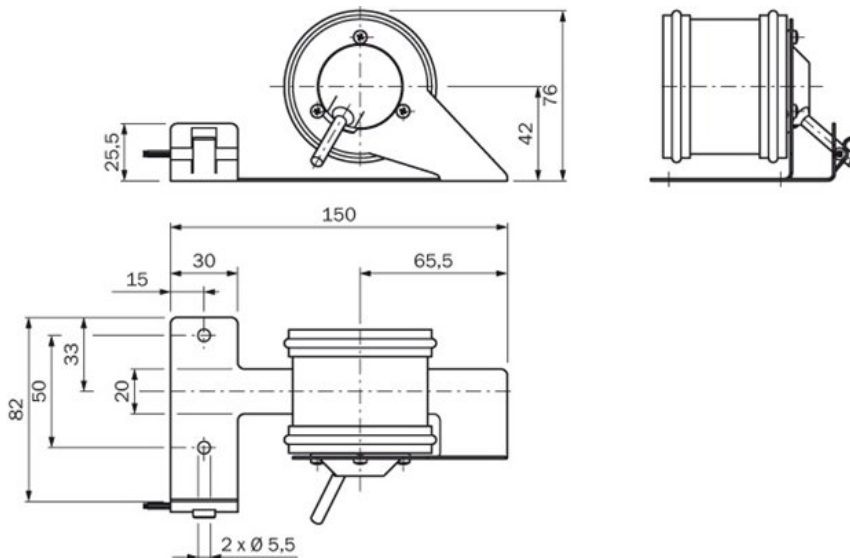

Proposed fitting

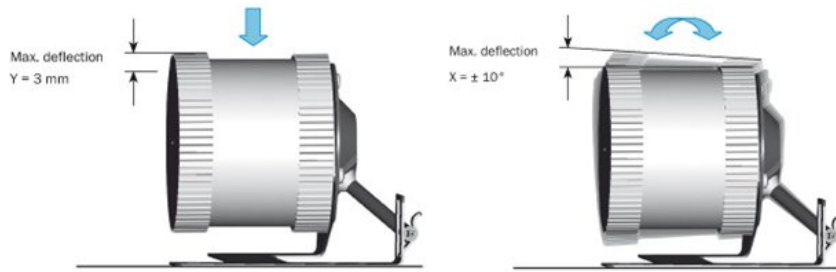

PIN assignment

View of the connector side of housing

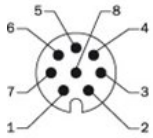

PIN, 8-pin, connector M12	Color of wires	Signal TTL, HTL	Explanation
1	Brown	\bar{A}	Signal line
2	White	A	Signal line
3	Black	\bar{B}	Signal line
4	Pink	B	Signal line
5	Yellow	\bar{Z}	Signal line
6	Lilac	Z	Signal line
7	Blue	GND	Ground connection of the encoder
8	Red	+U _s	Supply voltage, potential free to the housing
Screen	Screen	Screen	Screen connected to encoder housing

Signalausgänge

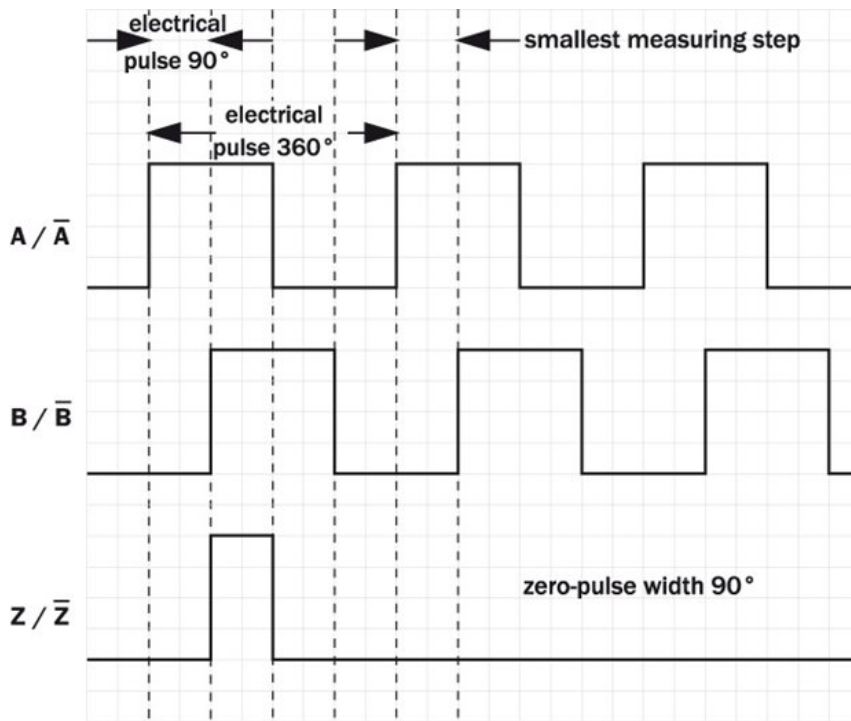

Australia

Phone +61 3 9457 0600
1800 334 802 – tollfree
E-Mail sales@sick.com.au

Belgium/Luxembourg

Phone +32 (0)2 466 55 66
E-Mail info@sick.be

Brasil

Phone +55 11 3215-4900
E-Mail sac@sick.com.br

Canada

Phone +1 905 771 14 44
E-Mail information@sick.com

Ceská Republika

Phone +420 2 57 91 18 50
E-Mail sick@sick.cz

China

Phone +86 4000 121 000
E-Mail info.china@sick.net.cn
Phone +852-2153 6300
E-Mail ghk@sick.com.hk

Danmark

Phone +45 45 82 64 00
E-Mail sick@sick.dk

Deutschland

Phone +49 211 5301-301
E-Mail kundenservice@sick.de

España

Phone +34 93 480 31 00
E-Mail info@sick.es

France

Phone +33 1 64 62 35 00
E-Mail info@sick.fr

Great Britain

Phone +44 (0)1727 831121
E-Mail info@sick.co.uk

India

Phone +91-22-4033 8333
E-Mail info@sick-india.com

Israel

Phone +972-4-6801000
E-Mail info@sick-sensors.com

Italia

Phone +39 02 27 43 41
E-Mail info@sick.it

Japan

Phone +81 (0)3 3358 1341
E-Mail support@sick.jp

Magyarország

Phone +36 1 371 2680
E-Mail office@sick.hu

Nederlands

Phone +31 (0)30 229 25 44
E-Mail info@sick.nl

Norge

Phone +47 67 81 50 00
E-Mail austefjord@sick.no

Österreich

Phone +43 (0)22 36 62 28 8-0
E-Mail office@sick.at

Polska

Phone +48 22 837 40 50
E-Mail info@sick.pl

România

Phone +40 356 171 120
E-Mail office@sick.ro

Russia

Phone +7-495-775-05-30
E-Mail info@sick.ru

Schweiz

Phone +41 41 619 29 39
E-Mail contact@sick.ch

Singapore

Phone +65 6744 3732
E-Mail admin@sicksgp.com.sg

Slovenija

Phone +386 (0)1-47 69 990
E-Mail office@sick.si

South Africa

Phone +27 11 472 3733
E-Mail info@sickautomation.co.za

South Korea

Phone +82 2 786 6321/4
E-Mail info@sickkorea.net

Suomi

Phone +358-9-25 15 800
E-Mail sick@sick.fi

Sverige

Phone +46 10 110 10 00
E-Mail info@sick.se

Taiwan

Phone +886-2-2375-6288
E-Mail sales@sick.com.tw

Türkiye

Phone +90 (216) 528 50 00
E-Mail info@sick.com.tr

United Arab Emirates

Phone +971 (0) 4 8865 878
E-Mail info@sick.ae

USA/México

Phone +1(952) 941-6780
1 800-325-7425 – tollfree
E-Mail info@sickusa.com

More representatives and agencies
at www.sick.com