

**Inductive sensor  
power clamp monitor  
NI2-Q9,5-AP6-0,1-FS4.4X3/S304**

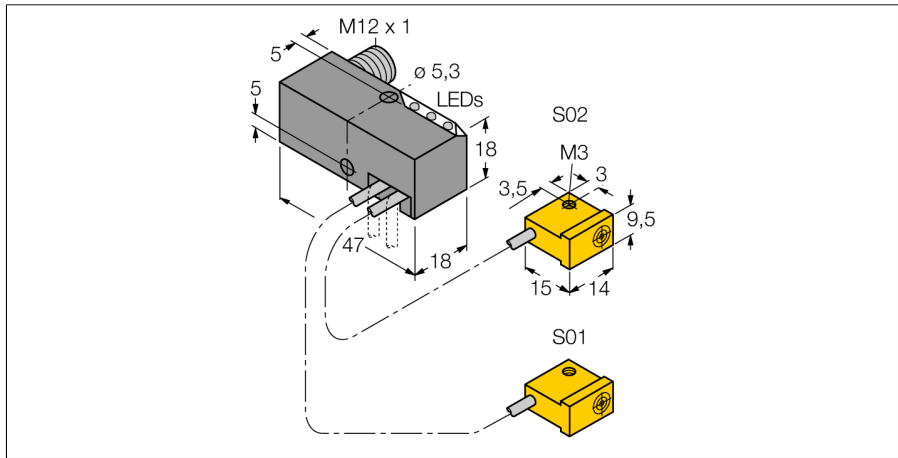

- Q9,5 power block with two connected sensors and LEDs
- Adaptable block position 0°...90°, with cross drilling for flexible cable routing
- Plastic, PP GR-20
- Magnetic field immune (weld-resistant) to DC and AC fields
- 2 x NO contact, PNP output
- 4-wire DC, 10...30 VDC

**Wiring diagram**

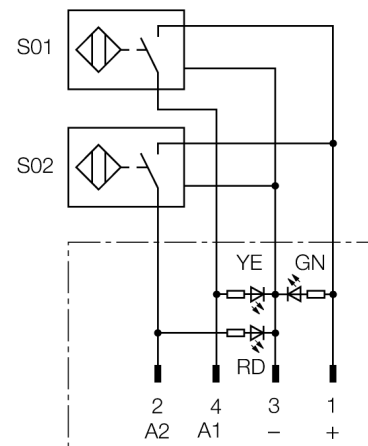

**Functional principle**

TURCK offers special monitoring kits, consisting of two miniature sensors, as a convenient solution for "Open/Closed" detection on pneumatic power clamps. This product line provides almost unlimited combination possibilities, comprising four different power blocks and over forty different modular sensor types.

<b>Type code</b>	NI2-Q9,5-AP6-0,1-FS4.4X3/S304
Ident no.	1650060
<b>Rated operating distance Sn</b>	2 mm
Mounting condition	non-flush
Assured sensing range	≤ (0,81 x Sn) mm
Correction factors	St37 = 1; Al = 0.3; stainless steel = 0.7; Ms = 0.4
Repeatability	≤ 2 % of full scale
Temperature drift	10 %
Hysteresis	3...15 %
Ambient temperature	-25...+70 °C
<b>Operating voltage</b>	10...30VDC
Residual ripple	≤ 10 % U <sub>ss</sub>
DC rated operational current	≤ 150 mA
No-load current I <sub>0</sub>	≤ 20 mA
Residual current	≤ 0.1 mA
Rated insulation voltage	≤ 0.5 kV
Short-circuit protection	yes/ cyclic
Voltage drop at I <sub>0</sub>	≤ 1.8 V
Wire breakage / Reverse polarity protection	yes/ complete
Output function	4-wire, NO contact, PNP
Smallest operating current I <sub>m</sub>	≤ 1 mA
Switching frequency	0.03 kHz
<b>Design</b>	monitoring kit for clamping technology, Q9.5
Dimensions	47 x 18 x 18 mm
Housing material	metal, PBT
Material active area	Plastic, PP
Connection	male, M12 x 1
Cable quality	2 mm, grey, Lif9Y-11Y, PUR, 0.1 m
Cable cross section	3 x 0.08 mm <sup>2</sup>
Litz wire	40x0.05mm <sup>2</sup>
Vibration resistance	55 Hz (1 mm)
Shock resistance	30 g (11 ms)
Protection class	IP67
MTTF	2283 years acc. to SN 29500 (Ed. 99) 40 °C
<b>Power-on indication</b>	LED green
Switching state	LED yellow / red

**Inductive sensor  
power clamp monitor  
NI2-Q9,5-AP6-0,1-FS4.4X3/S304**

Mounting instructions / Description	minimum distances
Distance D	3 x B
Distance W	3 x Sn
Distance S	1.5 x B
Distance G	6 x Sn
Distance N	2 x Sn

---

<b>Width of the active face B</b>	6.5 mm
-----------------------------------	--------

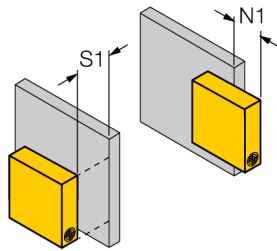

**Please note, non-flush mounting of this sensor is obligatory.**

The following conditions allow semi-flush mounting:

N1 = 0 mm and S1 = 1 mm or

N1 = 1 mm and S1 = 0 mm

These values apply for mounting in aluminium

N1 = 0 mm and S1 = 5 mm or

N1 = 5 mm and S1 = 0 mm

These values apply for mounting in St37.

**Inductive sensor  
power clamp monitor  
NI2-Q9,5-AP6-0,1-FS4.4X3/S304**

**Wiring accessories**

Type code	Ident no.	Description	Dimension drawing
RKC4.4T-2/TEL	6625013	Connection cable, female M12, straight, 4-pin, cable length: 2 m, sheath material: PVC, black; cULus approval; other cable lengths and qualities available, see <a href="http://www.turck.com">www.turck.com</a>	