



OVERLOAD RELAY 25...100 A FOR MOTOR PROTECTION SIZE S3, CLASS 20 STAND-ALONE INSTALLATION MAIN CIRCUIT: THROUGH TRANSF. AUX. CIRCUIT: SPRINGLOAD. TERM. MANUAL-AUTOMATIC-RESET

General technical data:

product brand name		SIRIUS
Product designation		solid-state overload relay
Size of overload relay		S3
Number of poles / for main current circuit		3
Product function / removable terminal for auxiliary and control circuit		Yes
Impulse voltage resistance / rated value	kV	8
Protection class IP		IP20
Protection class IP / on the front		IP20
Protection against electrical shock		finger-safe
Installation altitude / at a height over sea level / maximum	m	2,000
Resistance against shock		15g / 11 ms
Ambient temperature		
• during transport	°C	-40 ... +80
• during storage	°C	-40 ... +80
• during operating	°C	-25 ... +60
Relative humidity / during operating phase / maximum	%	100
Electrostatic discharge / according to IEC 61000-4-2		6 kV contact discharge / 8 kV air discharge
Field-bound parasitic coupling / according to IEC 61000-4-3		10 V/m

Conductor-bound parasitic coupling BURST / according to IEC 61000-4-4		2 kV (power ports), 1 kV (signal ports) corresponds to degree of severity 3
Conductor-bound parasitic coupling conductor-earth SURGE / according to IEC 61000-4-5		2 kV (line to earth) corresponds to degree of severity 3
Conductor-bound parasitic coupling conductor-conductor SURGE / according to IEC 61000-4-5		1 kV (line to line) corresponds to degree of severity 3
Type of protection		PTB 06 ATEX 3001 Ex II (2) GD
Active power loss / total / typical	W	0.05
Size of the contactor / can be combined / company-specific		S3

Main circuit:

Operating current / of the fuse link / rated value	A	315
Type of assignment		2

Auxiliary circuit:

Number of NC contacts / for auxiliary contacts		1
Number of NO contacts / for auxiliary contacts		1
Number of changeover contacts / for auxiliary contacts		0
Design of the fuse link / for short-circuit protection of the auxiliary switch / required		fuse gL/gG: 6 A
Operating current / of the auxiliary contacts		
• at AC-15		
• at 24 V	A	4
• at 110 V	A	4
• at 120 V	A	4
• at 125 V	A	4
• at 230 V	A	3
• at DC-13		
• at 24 V	A	2
• at 60 V	A	0.55
• at 110 V	A	0.3
• at 125 V	A	0.3
• at 220 V	A	0.11

Protective and monitoring functions:

Trip class		CLASS 20
Adjustable response current / of the current-dependent overload release	A	25 ... 100

Installation/ mounting/ dimensions:











Mounting type		stand-alone installation
mounting position		any
Depth	mm	124

Height	mm	106
Width	mm	70

Connections/ terminals:

Design of the electrical connection <ul style="list-style-type: none"> • for main current circuit • for auxiliary and control current circuit 	straight-through transformers spring-loaded terminals
Type of the connectable conductor cross-section <ul style="list-style-type: none"> • for auxiliary contacts <ul style="list-style-type: none"> • solid • finely stranded <ul style="list-style-type: none"> • with conductor end processing • for AWG conductors / for auxiliary contacts 	2x (0.25 ... 1.5 mm ²) 2x (0.25 ... 1.5 mm ²) 2x (24 ... 16)

Certificates/ approvals:

General Product Approval			EMC	For use in hazardous locations	
 CCC	 CSA		 UL	 C-TICK	 ATEX
Test Certificates		Shipping Approval			
Type Test Certificates/Test Report		 ABS	 DNV	 GL	 LRS
				 RINA	
other					
Declaration of Conformity		other		Environmental Confirmations	

Further information:

Information- and Downloadcenter (Catalogs, Brochures,...)

<http://www.siemens.com/industrial-controls/catalogs>

Industry Mall (Online ordering system)

<http://www.siemens.com/industrial-controls/mall>

Cax online generator

<http://www.siemens.com/cax>

Service&Support (Manuals, Certificates, Characteristics, FAQs,...)

<http://support.automation.siemens.com/WW/view/en/3RB2046-2EX1/all>

Image database (product images, 2D dimension drawings, 3D models, device circuit diagrams, ...)

http://www.automation.siemens.com/bilddb/cax_en.aspx?mlfb=3RB2046-2EX1

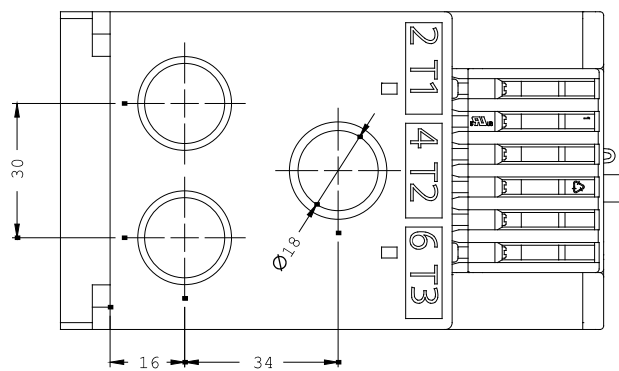
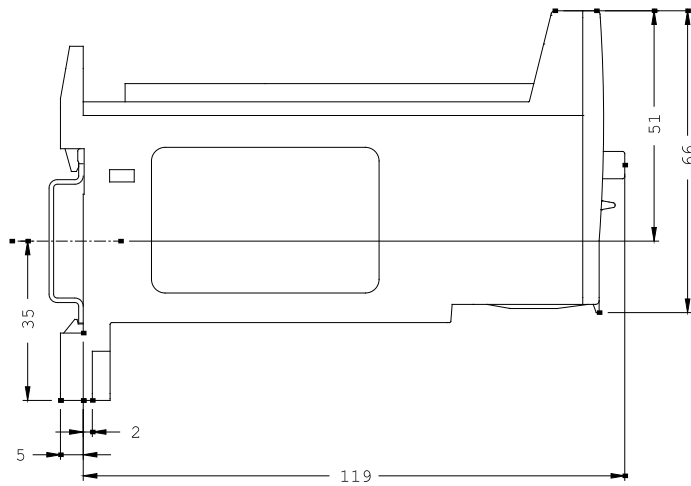
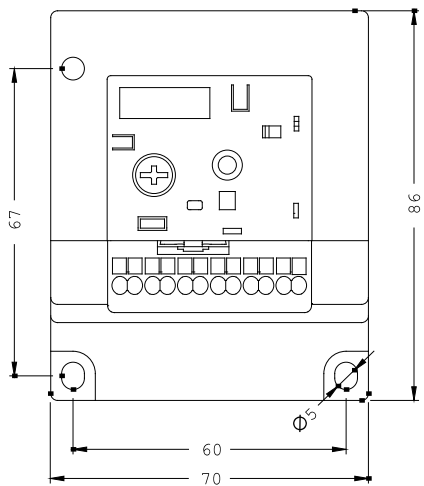

last change:

Jun 16, 2014