

- Rectangular, height 12 mm
- Plastic, PBT-GF30-V0
- Resistant to magnetic fields
- Factor 1 for all metals
- High sensitivity ensures detection of small parts
- Output pulse length min. 100 ms
- 3-wire DC, 10...30 VDC
- NO contact, PNP output
- Male M8 x 1

Wiring diagram

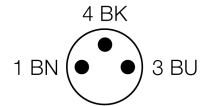
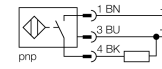

Type code	WN123462
Ident no.	1646644
Rated operating distance Sn	20 mm
Fly-by speed	0...20 m/s
Mounting condition	non-flush
Assured sensing range	≤ (0,81 x Sn) mm
Repeatability	≤ 2 % of full scale
pulse stop	≥ 5 ms
Pulse duration at the output	100 ms ± 20 %
Temperature drift	10 %
Hysteresis	3...15 %
Ambient temperature	-25...+70 °C
Operating voltage	10...30VDC
Residual ripple	≤ 10 % U _s
DC rated operational current	≤ 200 mA
No-load current I ₀	≤ 15 mA
Residual current	≤ 0.1 mA
Rated insulation voltage	≤ 0.5 kV
Short-circuit protection	yes/ cyclic
Voltage drop at I ₀	≤ 1.8 V
Wire breakage / Reverse polarity protection	yes/ complete
Output function	3-wire, NO contact, PNP
Switching frequency	0.008 kHz
Design	rectangular, TS12
Dimensions	80 x 17 x 12 mm
Housing material	plastic, PBT
Connection	male, M8 x 1
Vibration resistance	55 Hz (1 mm)
Shock resistance	30 g (11 ms)
Protection class	IP68
MTTF	874 years acc. to SN 29500 (Ed. 99) 40 °C
Power-on indication	LED green
Switching state	LED yellow
Included in scope of supply	2 retaining straps

Functional principle

The highly sensitive sensor detects even small and fast tube-guided parts. Easily mounted with retaining straps. Can be re-positioned or replaced during operation. High-quality alternative to simple ring sensors.

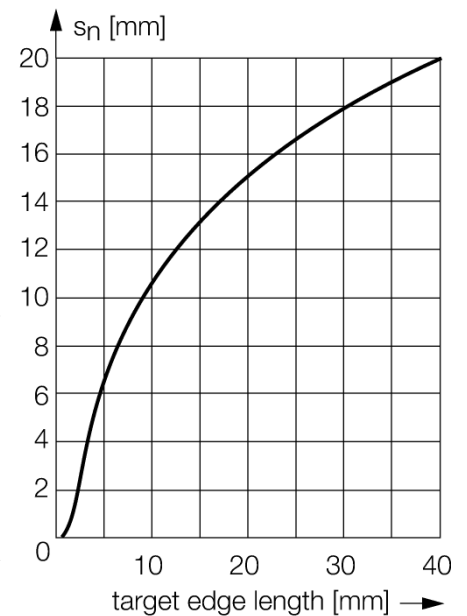

Distance D	50 mm
Distance W	35 mm
Distance S	35 mm
Distance A	42 mm
Distance C	30 mm
<hr/>	
Width of the active face B	17 mm

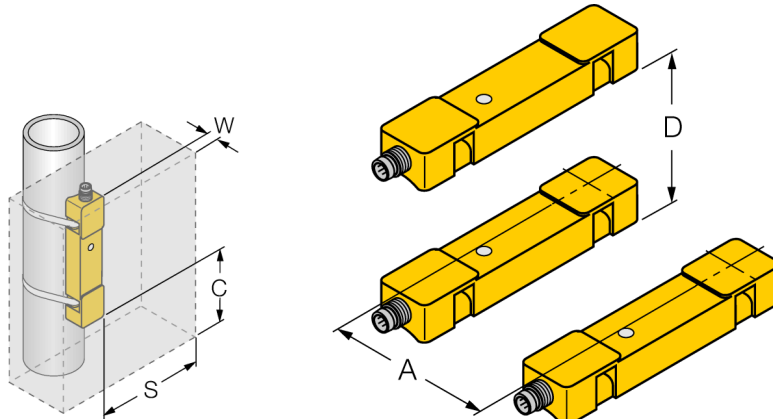

The TS12 has no tailback detection function.

To achieve optimal functionality, use only small targets with a max. length of 20 mm.