

Inductive sensor
NI25-Q20-AN6X2-H1141

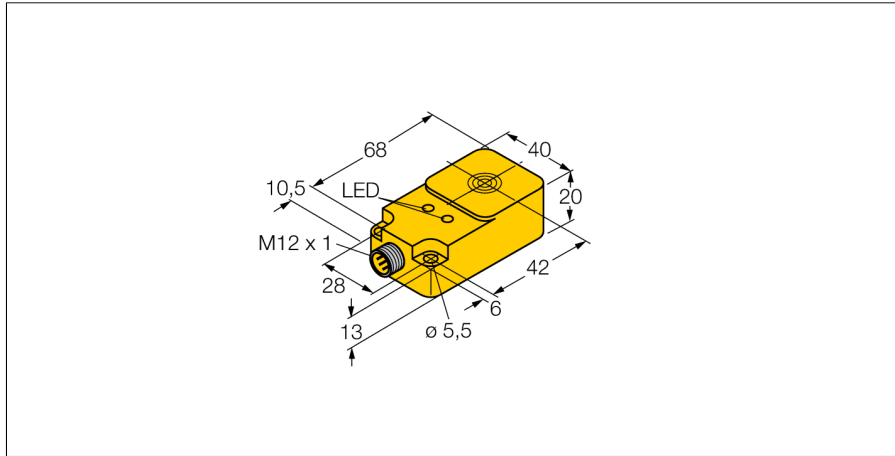

- Rectangular, height 20 mm
- Active face on top
- Plastic, PBT-GF30-V0
- 3-wire DC, 10...30 VDC
- NO contact, NPN output
- Male M12 x 1

Wiring diagram

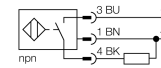

Type code	NI25-Q20-AN6X2-H1141
Ident no.	1602802
Rated operating distance Sn	25 mm
Mounting condition	non-flush
Assured sensing range	≤ (0,81 x Sn) mm
Correction factors	St37 = 1; Al = 0.3; stainless steel = 0.7; Ms = 0.4
Repeatability	≤ 2 % of full scale
Temperature drift	10 %
Hysteresis	3...15 %
Ambient temperature	-25...+70 °C
Operating voltage	10...30VDC
Residual ripple	≤ 10 % U _{ss}
DC rated operational current	≤ 200 mA
No-load current I ₀	≤ 15 mA
Residual current	≤ 0.1 mA
Rated insulation voltage	≤ 0.5 kV
Short-circuit protection	yes/ cyclic
Voltage drop at I ₀	≤ 1.8 V
Wire breakage / Reverse polarity protection	yes/ complete
Output function	3-wire, NO contact, NPN
Switching frequency	0.25 kHz
Design	rectangular, Q20
Dimensions	68 x 40 x 20 mm
Housing material	plastic, PBT
Connection	male, M12 x 1
Vibration resistance	55 Hz (1 mm)
Shock resistance	30 g (11 ms)
Protection class	IP67
MTTF	2283 years acc. to SN 29500 (Ed. 99) 40 °C
Power-on indication	LED green
Switching state	LED yellow

Functional principle

Inductive sensors detect metal objects contactless and wear-free. For this, they use a high-frequency electromagnetic AC field that interacts with the target. Inductive sensors generate this field via an RLC circuit with a ferrite coil.

We offer special versions for temperatures of -60 °C up to +250 °C.

**Inductive sensor
NI25-Q20-AN6X2-H1141**

Distance W	3 x Sn
Distance S	1.5 x B
Distance G	6 x Sn
Distance N	2 x Sn
Distance A	1 x Sn
Distance C	2 x Sn
Width of the active face B	40 mm



Inductive sensor
NI25-Q20-AN6X2-H1141

Accessories

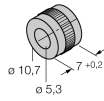
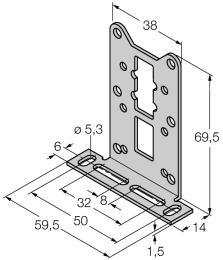
Type code	Ident no.	Description	Dimension drawing
MH-Q20MONTAGEHÜLSEN	6950010	Mounted with active face downwards, for Q20	
MW-Q14/Q20	6945006	Mounting bracket for rectangular Q14 or Q20; material VA 1.4301	

Wiring accessories

Type code	Ident no.	Description	Dimension drawing
RKC4T-2/TEL	6625010	Connection cable, female M12, straight, 3-pin, cable length: 2 m, sheath material: PVC, black; cULus approval; other cable lengths and qualities available, see www.turck.com	