

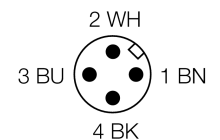

- ATEX category II 3 G, Ex Zone 2
- ATEX category II 3 D, Ex Zone 22
- Rectangular, height 40 mm
- Active face on top
- Plastic, PBT-GF30-V0
- Factor 1 for all metals
- Increased switching distance
- Protection class IP68
- Resistant to magnetic fields
- 4-wire DC, 10...65 VDC
- Changeover contact, PNP output
- Male M12 x 1

Type code	BI50U-Q80-VP4X2-H1141/3GD
Ident no.	1562004
Rated operating distance Sn	50 mm
Mounting condition	flush
Assured sensing range	≤ (0,81 x Sn) mm
Repeatability	≤ 2 % of full scale
Temperature drift	10 %
Hysteresis	1...15 %
Ambient temperature	-25...+70 °C in the explosion hazardous area see instruction leaflet
Operating voltage	10...65VDC
Residual ripple	≤ 10 % U _{in}
DC rated operational current	≤ 200 mA
No-load current I ₀	≤ 15 mA
Residual current	≤ 0.1 mA
Rated insulation voltage	≤ 0.5 kV
Short-circuit protection	yes
Voltage drop at I ₀	≤ 1.8 V
Wire breakage / Reverse polarity protection	yes/ complete
Output function	4-wire, changover contact, PNP
Protection class	□
Switching frequency	0.25 kHz
Approval acc. to	ATEX test certificate TURCK Ex-10002M X
Device designation	Ⓔ II 3 G Ex nA IIC T4 Gc/II 3 D Ex tIIIc T110°C Dc
Design	rectangular, Q80
Dimensions	92 x 80 x 40 mm
Housing material	plastic, PBT
Connection	male, M12 x 1
Vibration resistance	55 Hz (1 mm)
Shock resistance	30 g (11 ms)
Protection class	IP68
MTTF	874 years acc. to SN 29500 (Ed. 99) 40 °C
Power-on indication	LED green
Switching state	LED yellow

Wiring diagram

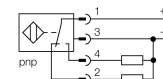

Functional principle

Inductive sensors detect metal objects contactless and wear-free. Due to the patented multi-coil system, *uprox*®+ sensors have distinct advantages over conventional sensors. They excel in largest switching distances, maximum flexibility and operational reliability as well as efficient standardization.

Distance D	240 mm
Distance W	150 mm
Distance S	80 mm
Distance G	300 mm

Width of the active face B 80 mm

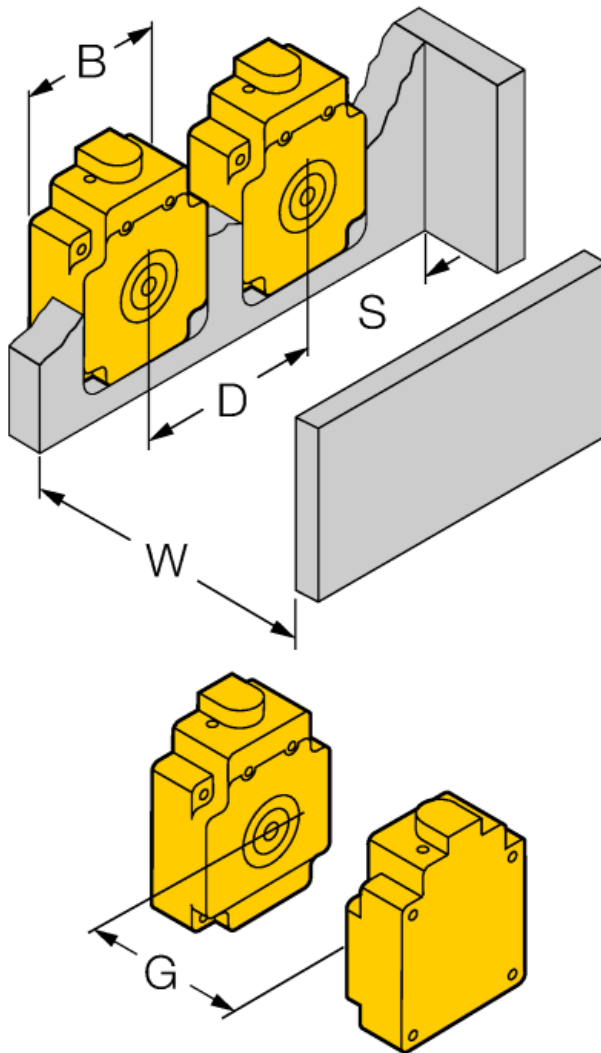

Wiring accessories

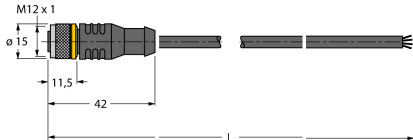
Type code	Ident no.	Description	Dimension drawing
RKC4.4T-2/TEL	6625013	Connection cable, female M12, straight, 4-pin, cable length: 2 m, sheath material: PVC, black; cULus approval; other cable lengths and qualities available, see www.turck.com	

Operating manual

Intended use

This device fulfills the directive 94/9/EC and is suited for use in explosion hazardous areas according to EN60079-0:2009, EN60079-15:2010 and EN60079-31:2009.

In order to ensure correct operation to the intended purpose it is required to observe the national regulations and directives.

For use in explosion hazardous areas conform to classification

II 3 G and II 3 D (Group II, Category 3 G, electrical equipment for gaseous atmospheres and category 3 D, electrical equipment for dust atmospheres).

Marking (see device or technical data sheet)

Ⓔ II 3 G Ex nA IIC T4 Gc acc. to EN 60079-0:2009 and EN 60079-15:2010 and Ⓔ II 3 D Ex t IIC T110°C Dc acc. to EN 60079-0:2009 and EN 60079-31:2009

Local admissible ambient temperature

-25...+70 °C

Installation / Commissioning

These devices may only be installed, connected and operated by trained and qualified staff. Qualified staff must have knowledge of protection classes, directives and regulations concerning electrical equipment designed for use in explosion hazardous areas.

Please verify that the classification and the marking on the device comply with the actual application conditions.

Installation and mounting instructions

Avoid static charging of cables and plastic devices. Please only clean the device with a damp cloth. Do not install the device in a dust flow and avoid build-up of dust deposits on the device.

The devices must be protected against strong magnetic fields.

The pin configuration and the electrical specifications can be taken from the device marking or the technical data sheet.

In order to avoid contamination of the device, please remove possible blanking plugs of the cable glands or connectors only shortly before inserting the cable or opening the cable socket.

Special conditions for safe operation

For devices with M12 connectors please use the supplied safety clip SC-M12/3GD.

Do not disconnect the plug-in connection or cable when energised.

Please attach a warning label permanently in an appropriate fashion in close proximity to the plug-in connection with the following inscription:

Nicht unter Spannung trennen / Do not separate when energized.

The device must be protected against any kind of mechanical damage and degrading UV-radiation.

The connectors are fully IP rated only in combination with the O-ring.

Load voltage and operating voltage of this equipment must be provided by power supplies featuring safe isolation (IEC 60 364/ UL 508), which ensures that the rated voltage (24 VDC +20% = 28.8 VDC) of the equipment is not exceeded by more than 40%.

service / maintenance

Repairs are not possible. The approval expires if the device is repaired or modified by a person other than the manufacturer. The most important data from the approval are listed.