

- Rectangular, height 38 mm
- Active face on top
- Plastic, PBT-GF30-V0
- Factor 1 for all metals
- Resistant to magnetic fields
- Extended temperature range
- 3-wire DC, 10...30 VDC
- NO contact, PNP output
- Male M12 x 1

#### Wiring diagram



#### General description

The Q40 series is specially designed for position control of pieces in large pressing tools. The height of the sensor can be altered with the screw. Recessed mounting protects the sensor against mechanical damage.

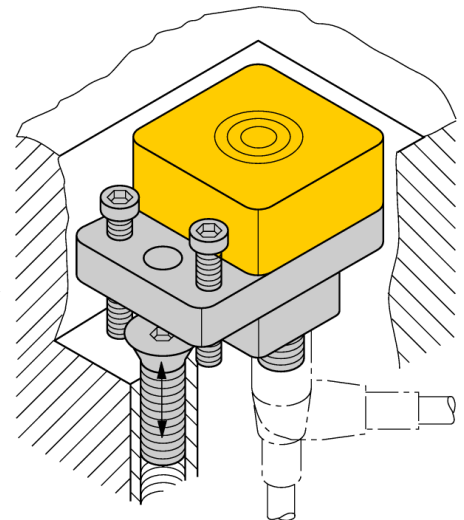

<b>Type code</b>	NI22U-Q40-AP6X2-H1141
Ident no.	4690229
<b>Rated operating distance Sn</b>	22 mm
Mounting condition	non-flush, recessible in press tool
Assured sensing range	≤ (0,81 x Sn) mm
Repeatability	≤ 2 % of full scale
Temperature drift	10 %
Hysteresis	3...15 %
Ambient temperature	0...+70 °C
<b>Operating voltage</b>	10...30VDC
Residual ripple	≤ 10 % U <sub>ss</sub>
DC rated operational current	≤ 200 mA
No-load current I <sub>0</sub>	≤ 15 mA
Residual current	≤ 0.1 mA
Rated insulation voltage	≤ 0.5 kV
Short-circuit protection	yes/ cyclic
Voltage drop at I <sub>0</sub>	≤ 1.8 V
Wire breakage / Reverse polarity protection	yes/ complete
Output function	3-wire, NO contact, PNP
Protection class	□
Switching frequency	0.25 kHz
<b>Design</b>	rectangular, Q40
Dimensions	67 x 40 x 52.5 mm
Housing material	plastic, PBT
Connection	male, M12 x 1
Vibration resistance	55 Hz (1 mm)
Shock resistance	30 g (11 ms)
Protection class	IP68
MTTF	874 years acc. to SN 29500 (Ed. 99) 40 °C
<b>Power-on indication</b>	LED green
Switching state	LED yellow

Distance D

240 mm

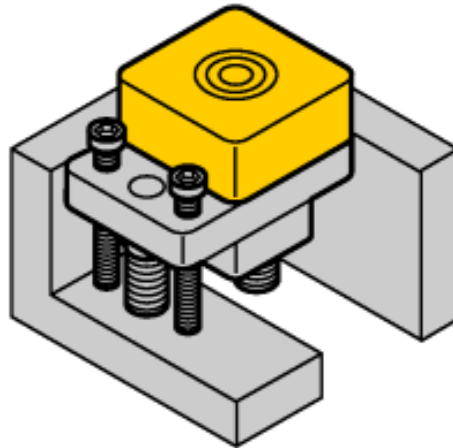
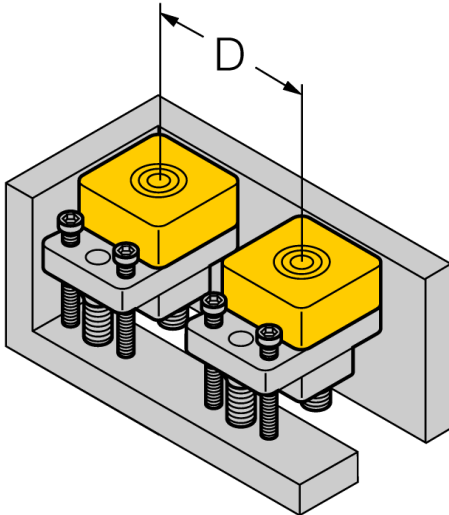

Non-flush mounting  $S_r = 22 \text{ mm}$

Screw in the base such that the switching distance can be reduced to 10 mm.

Recessed mounting  $S_r = 19 \text{ mm}$   
1 mm beneath the tool contour

Screw in the base such that the switching distance can be reduced to 10 mm.

Recessed mounting  $S_r = 21 \text{ mm}$   
11 mm beneath the tool contour

Use the screws to modify the mounting depth.

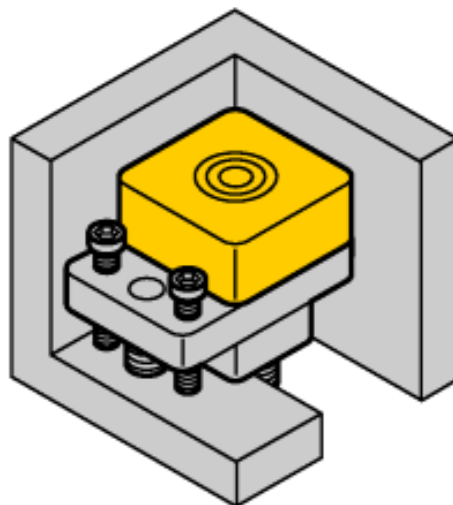
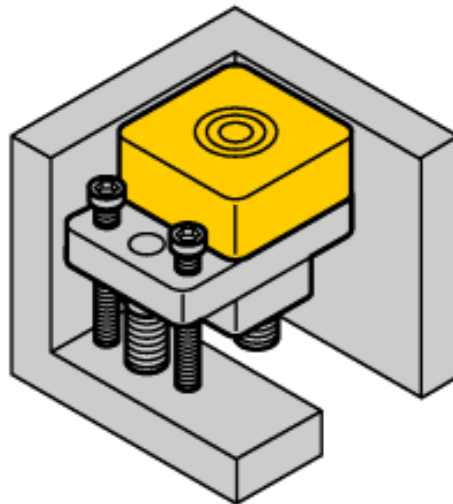

**Wiring accessories**

Type code	Ident no.	Description	Dimension drawing
RKC4T-2/TEL	6625010	Connection cable, female M12, straight, 3-pin, cable length: 2 m, sheath material: PVC, black; cULus approval; other cable lengths and qualities available, see <a href="http://www.turck.com">www.turck.com</a>	