

**Inductive sensor  
for material recognition  
NI100R-S32XL-2LU-H1141/S950**

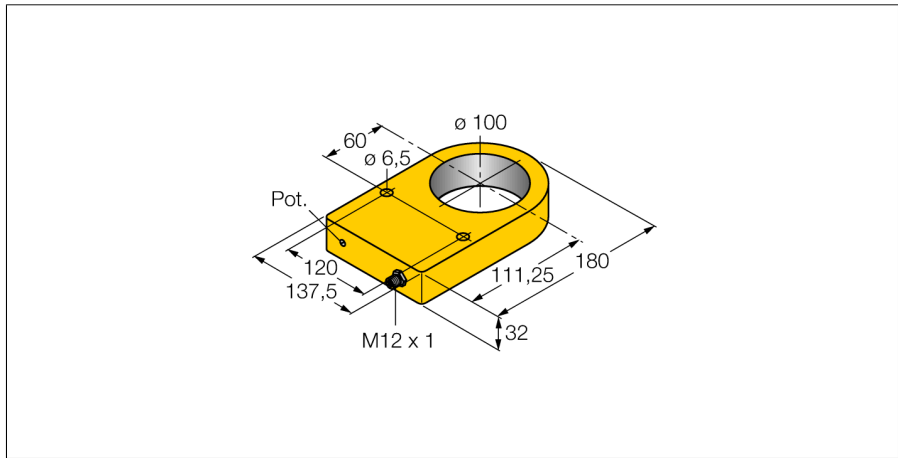

- Rectangular, height 32 mm
- Plastic, POM
- Analog
- 1 x analog output for amplitude evaluation
- 1 x analog output for phase evaluation
- Male M12 x 1

**Wiring diagram**

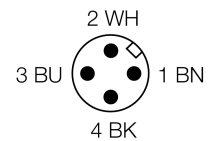
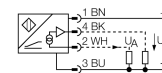

<b>Type code</b>	NI100R-S32XL-2LU-H1141/S950
Ident no.	1534610
<b>Inside ring diameter D</b>	100 mm
Measuring range [A...B]	depending on the length of the cone ≤ 0.5 %, after warm-up 0.5 h
Temperature drift	≤ ± 0.06 % / K
Ambient temperature	-25...+70 °C
<b>Operating voltage</b>	15...30VDC
Residual ripple	≤ 10 % U <sub>ss</sub>
No-load current I <sub>0</sub>	≤ 8 mA
Rated insulation voltage	≤ 0.5 kV
Short-circuit protection	yes
Wire breakage / Reverse polarity protection	yes/ complete
Output function	4-wire, Analog output
Voltage output	0...10V
Voltage output (phase)	≥ 1...≤ 10VDC
Load resistance voltage output	≥ 4.7 kΩ
Measuring sequence frequency	80 Hz
<b>Design</b>	ring sensor, S32XL
Dimensions	180 x 137.5 x 32 mm
Housing material	plastic, POM
Connection	male, M12 x 1
Coil body	plastic, POM
Vibration resistance	55 Hz (1 mm)
Shock resistance	30 g (11 ms)
Protection class	IP67
MTTF	751 years acc. to SN 29500 (Ed. 99) 40 °C

**Functional principle**

Many applications require a fast detection of material qualities. For example, the sorting of beverage cans made of aluminium or tin, or the differentiation of pipes made of different metals. Turck has developed an analog inductive sensor for this purpose that not only processes the amplitude signal but also the phase signal. Both signals are output as analog values and processed mathematically with a control unit. Different metals are thus detected independent of the distance.

**Inductive sensor  
for material recognition  
NI100R-S32XL-2LU-H1141/S950**

**TURCK**

Industrial  
Automation

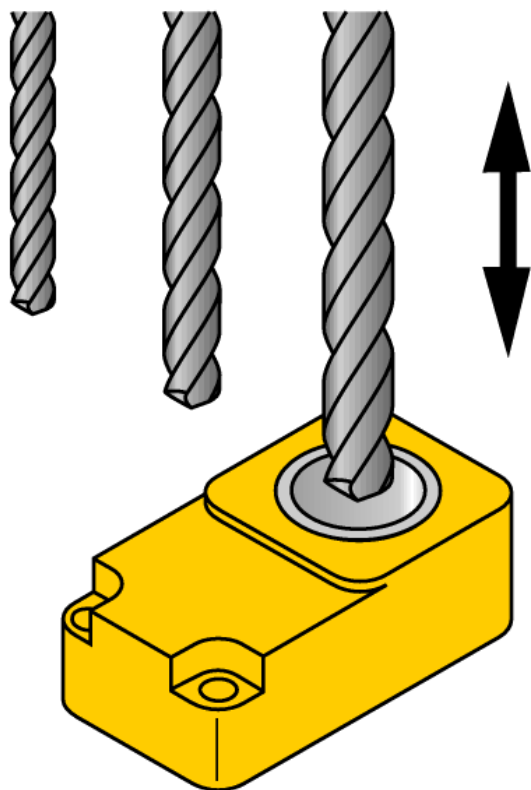

**Inductive sensor  
for material recognition  
NI100R-S32XL-2LU-H1141/S950**

**Wiring accessories**

Type code	Ident no.	Description	Dimension drawing
RKC4.4T-2/TEL	6625013	Connection cable, female M12, straight, 4-pin, cable length: 2 m, sheath material: PVC, black; cULus approval; other cable lengths and qualities available, see <a href="http://www.turck.com">www.turck.com</a>	