



SOLID STATE CONTACTOR 3-P. 3RF2 AC51 10 A 40
DEG. C 48-600 V / 4-30 V DC 3PH.-CONTROLLED SCREW
TERMINAL BLOCKING VOLTAGE 1200V

General technical data:		
product brand name		SIRIUS
product designation		solid-state contactor
Product function		zero-point switching
Number of poles / for main current circuit		3
Protection class IP		IP20
Product designation / _2 / of the accessories that can be ordered		converter
Manufacturer article number / _2 / of the accessories that can be ordered		3RF2900-0EA18
Ambient temperature		
• during operating	°C	-25 ... +60
• during storage	°C	-55 ... +80
Installation altitude / at a height over sea level / maximum	m	1,000
Resistance against vibration / according to IEC 60068-2-6		2g
Resistance against shock / according to IEC 60068-2-27		15g / 11 ms
Item designation		
• according to DIN 40719 extendable after IEC 204-2 / according to IEC 750		K
• according to DIN EN 61346-2		Q
Number of NC contacts / for auxiliary contacts		0

Number of NO contacts / for auxiliary contacts		0
Number of change-over switches / for auxiliary contacts		0

Main circuit:

Number of NO contacts / for main contacts		3
Number of NC contacts / for main contacts		0
Operating current / at AC-1 / at 400 V / rated value	A	10
Operating current / at AC-51 / rated value	A	10
Reverse current / of the thyristor	mA	10
Derating temperature	°C	40
Operating current / minimum	mA	500
Resistance against the impulse current / rated value	A	300
I ² t-level / maximum	A ² ·s	450
Operating voltage		
• at 50 Hz / at AC / rated value	V	48 ... 600
• at 60 Hz / at AC / rated value	V	48 ... 600
Working area related to the operating voltage		
• at 50 Hz / for AC	V	40 ... 660
• at 60 Hz / for AC	V	40 ... 660
Operating frequency		
• rated value	Hz	50 ... 60
Relative symmetrical tolerance / of the operation frequency	%	10
Insulation voltage / rated value	V	600
Voltage slew rate / at the thyristor / for main contacts / maximum permissible	V/μs	500
Block voltage / at the thyristor / for main contacts / maximum permissible	V	1,200
Fuse assignments	https://www.automation.siemens.com/cd-static/material/info/3RF24_eng.pdf	

Control circuit:

Type of voltage / of the controlled supply voltage		DC
Control supply voltage / 1		
• for DC	V	4 ... 30
Control supply voltage / for DC / final value for signal<0>-recognition	V	1
Tolerance of the line frequency	Hz	5
Control current		
• at minimum control supply voltage / for DC	mA	2
• for DC / rated value	mA	30

Installation/mounting/dimensions:





Type of mounting		screw and snap-on mounting onto 35 mm standard mounting rail
Type of fixing/fixation / series installation		Yes
Design of the thread / of the screw for fastening of the operating resource		M4
Tightening torque / of the screw for fastening of the operating resource	N·m	1.5
Width	mm	45
Height	mm	100
Depth	mm	104.5

Connections:

Design of the electrical connection / for main current circuit		screw-type terminals
Design of the thread / of the connection screw / for main contacts		M4
Tightening torque / for main contacts • with screw-type terminals	N·m	2 ... 2.5
Tightening torque (lbf·in) / for main contacts • with screw-type terminals	lbf·in	18 ... 22
Type of the connectable conductor cross-section • for main contacts <ul style="list-style-type: none"> • solid • finely stranded <ul style="list-style-type: none"> • with conductor end processing • for AWG conductors <ul style="list-style-type: none"> • for main contacts • for auxiliary and control contacts • for auxiliary and control contacts <ul style="list-style-type: none"> • solid • finely stranded <ul style="list-style-type: none"> • with conductor end processing • without conductor final cutting 		2x (1.5 ... 2.5 mm ²), 2x (2.5 ... 6 mm ²) 2x (1 ... 2.5 mm ²), 2x (2.5 ... 6 mm ²), 1x 10 mm ² 2x (14 ... 10) 1x (AWG 20 ... 12) 1x (0.5 ... 2.5 mm ²), 2x (0.5 ... 1.0 mm ²) 1x (0.5 ... 2.5 mm ²), 2x (0.5 ... 1.0 mm ²) 1x (0.5 ... 2.5 mm ²), 2x (0.5 ... 1.0 mm ²)
Conductor cross section that can be connected • for main contacts <ul style="list-style-type: none"> • solid • stranded wire <ul style="list-style-type: none"> • with conductor end processing • for auxiliary and control contacts <ul style="list-style-type: none"> • solid • stranded wire <ul style="list-style-type: none"> • with conductor end processing / 	mm ² mm ² mm ² mm ²	1.5 ... 6 1 ... 10 0.5 ... 2.5 0.5 ... 2.5

• without conductor final cutting	mm ²	0.5 ... 2.5
AWG number / as coded connectable conductor cross-section / for main contacts		14 ... 10
Design of the electrical connection / for auxiliary and control current circuit		screw-type terminals
Design of the thread / of the connection screw / of the auxiliary and control pins		M3
AWG number / as coded connectable conductor cross-section • for auxiliary and control contacts		20 ... 12
Skinning length / of the cable / for main contacts	mm	7
Skinning length / of the cable / for auxiliary and control contacts	mm	7
Tightening torque / for auxiliary and control contacts • with screw-type terminals	N·m	0.5 ... 0.6
Tightening torque (lbf-in) / for auxiliary and control contacts • with screw-type terminals	lbf-in	7.5 ... 5.3

Certificates/approvals:

General Product Approval	EMC	Declaration of Conformity	Test Certificates
 CSA	 GOST	 UL	 C-TICK
		 EG-Konf.	Type Test Certificates/Test Report

other

[Environmental Confirmations](#)

Further information:

Information- and Downloadcenter (Catalogs, Brochures,...)

<http://www.siemens.com/industrial-controls/catalogs>

Industry Mall (Online ordering system)

<http://www.siemens.com/industrial-controls/mall>

Cax online generator:

<http://www.siemens.com/cax>

Service&Support (Manuals, Certificates, Characteristics, FAQs,...)

<http://support.automation.siemens.com/WW/view/en/3RF2410-1AC45/all>

Image database (product images, 2D dimension drawings, 3D models, device circuit diagrams, ...)

http://www.automation.siemens.com/bilddb/cax_en.aspx?mlfb=3RF2410-1AC45

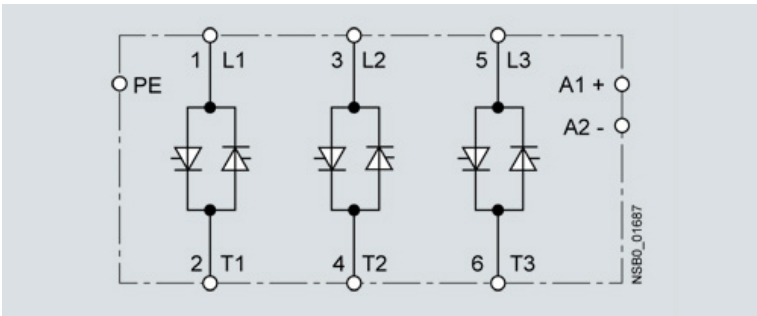
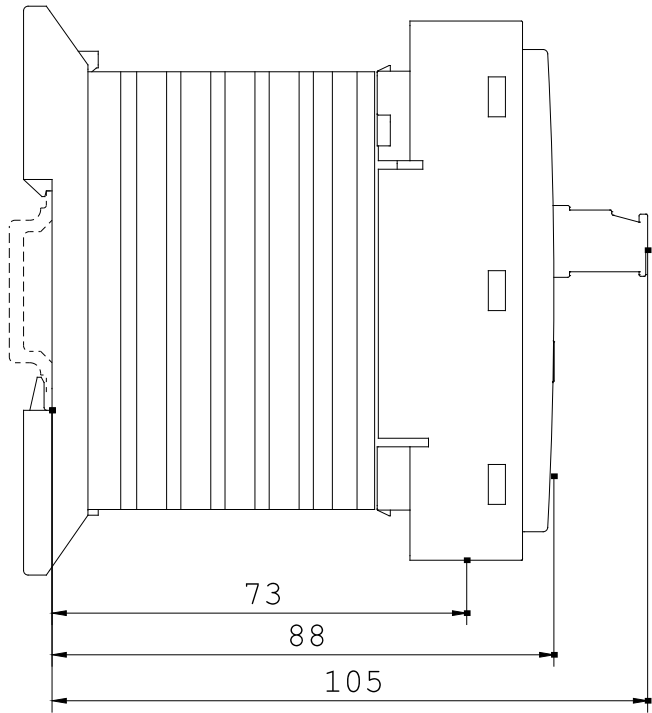
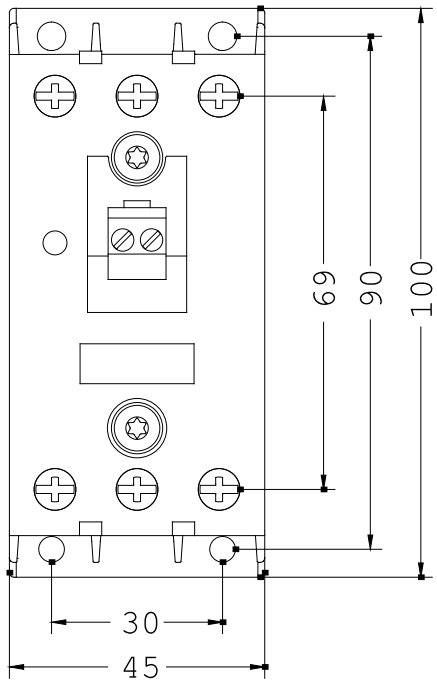

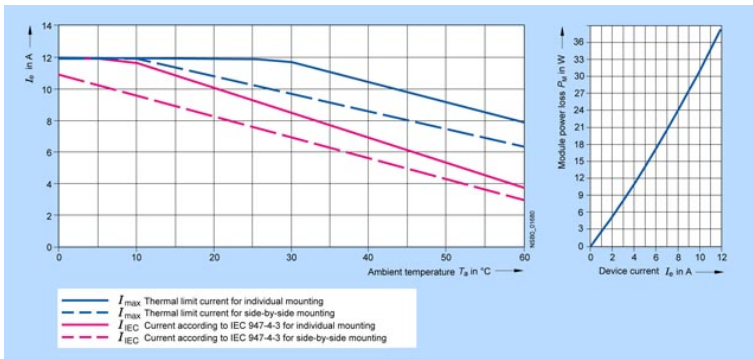
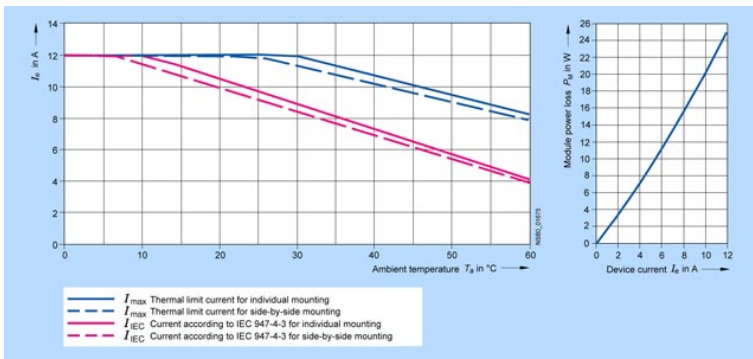

PE
M 5 x 10
1,5 Nm
(13 lb · in)

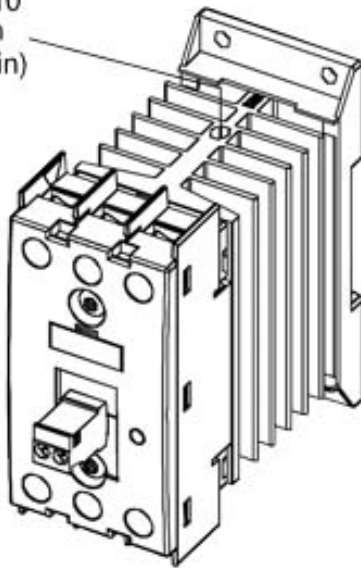

last change:

Feb 4, 2013