

- Threaded barrel, M12x1
- Stainless steel, 1.4301
- Factor 1 for all metals
- Protection class IP68
- Resistant to magnetic fields
- Extended temperature range
- High switching frequency
- 4-wire DC, 10...65 VDC
- Changeover contact, NPN output
- Cable connection

**Wiring diagram**

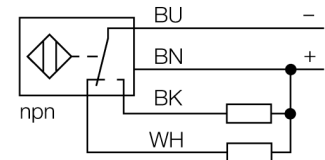

**Functional principle**

Inductive sensors detect metal objects contactless and wear-free. Due to the patented multicoil system, *uprox®*+ sensors have distinct advantages over conventional sensors. They detect all metals at the same large switching distance and are resistant to magnetic fields.

<b>Type code</b>	BI3U-EM12E-VN4X
Ident no.	1580362
<b>Rated operating distance Sn</b>	3 mm
Mounting condition	flush
Assured sensing range	≤ (0,81 x Sn) mm
Repeatability	≤ 2 % of full scale
Temperature drift	10 %
	≤ ± 15 %, ≤ -25 °C v ≥ +70 °C
Hysteresis	3...15 %
Ambient temperature	-30...+85 °C
<b>Operating voltage</b>	10...65VDC
Residual ripple	≤ 10 % U <sub>ss</sub>
DC rated operational current	≤ 200 mA
No-load current I <sub>0</sub>	≤ 15 mA
Residual current	≤ 0.1 mA
Rated insulation voltage	≤ 0.5 kV
Short-circuit protection	yes/ cyclic
Voltage drop at I <sub>e</sub>	≤ 1.8 V
Wire breakage / Reverse polarity protection	yes/ complete
Output function	4-wire, changover contact, NPN
Protection class	☐
Switching frequency	3 kHz
<b>Design</b>	threaded barrel, M12 x 1
Dimensions	64 mm
Housing material	stainless steel, V2A (1.4301)
Material active area	Plastic, PBT
End cap	Plastic, EPTR
Max. tightening torque housing nut	10 Nm
Connection	cable
Cable quality	5.2 mm, LifYY, PVC, 2 m
Cable cross section	4 x 0.34 mm <sup>2</sup>
Vibration resistance	55 Hz (1 mm)
Shock resistance	30 g (11 ms)
Protection class	IP68
MTTF	874 years acc. to SN 29500 (Ed. 99) 40 °C
<b>Switching state</b>	LED yellow

**Inductive sensor  
BI3U-EM12E-VN4X**

Distance D	2 x B
Distance W	3 x Sn
Distance T	3 x B
Distance S	1.5 x B
Distance G	6 x Sn
<hr/>	
Diameter of the active area B	Ø 12 mm

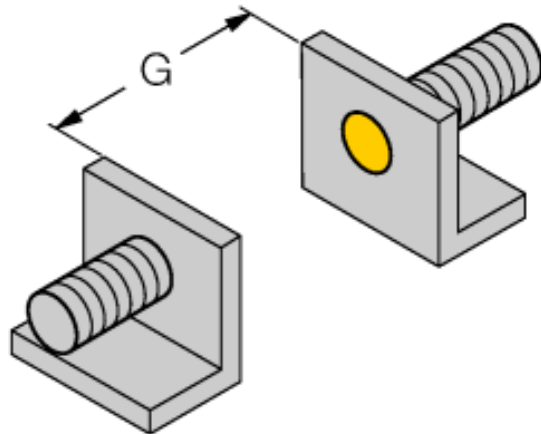

**Accessories**

Type code	Ident no.	Description	Dimension drawing
BST-12B	6947212	Fixing clamp for threaded barrel devices, with dead-stop; material: PA6	
QM-12	6945101	Quick-mount bracket with dead-stop; material: Chrome-plated brass Male thread M16 x 1. Note: The switching distance of proximity switches can be reduced by the use of quick-mount brackets.	
MW-12	6945003	Mounting bracket for threaded barrel devices; material: Stainless steel A2 1.4301 (AISI 304)	
BSS-12	6901321	Mounting bracket for smooth and threaded barrel devices; material: Polypropylene	