

**Inductive sensor
slip monitor
DBI5U-M18E-AP4X2 50/MIN**

Industrial
Automation

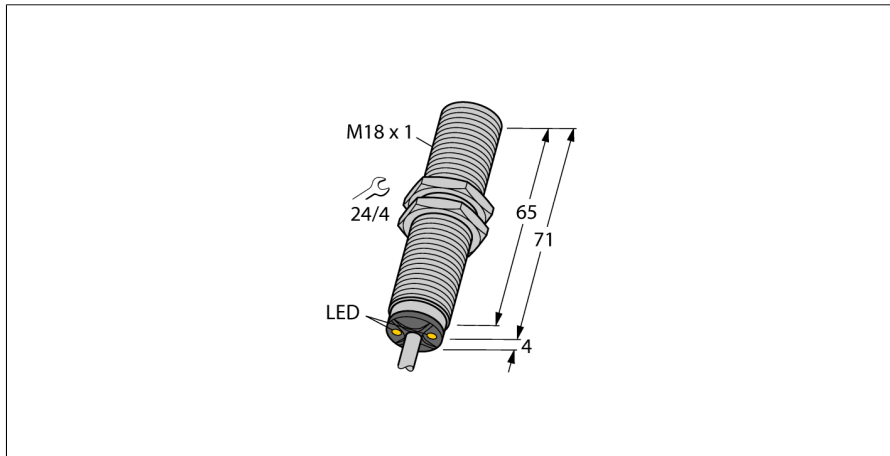

- Threaded barrel, M18 x 1
- Chrome-plated brass
- Monitoring range 50 1/min
- Fixed start-up time delay 5 s
- Factor 1 for all metals
- Magnetic field immune
- 3-wire DC, 10...65 VDC
- NO contact, PNP output
- Cable connection

Wiring diagram

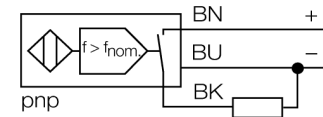

Functional principle

The rotational speed is detected by periodic damping of the integrated inductive sensor. This can be accomplished via metal targets or teeth on the monitored shaft. The pulse sequence generated is compared to an adjustable reference value in a comparator circuit. If the rotational speed is below the reference value, the output is switched off (0). If the reference value is exceeded, the output is switched on (1). The start-up time delay (AÜ) is triggered by applying voltage to the device and closes the output for 5 s (start-up time of the drive).

Diagram

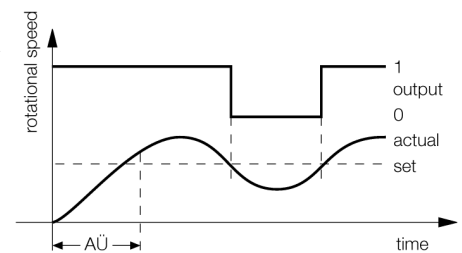

Type code	DBI5U-M18E-AP4X2 50/MIN
Ident no.	1582239
Rotational-speed range, fixed	50 1/min
Hysteresis (rotational-speed range)	3...15%
Rated operating distance S_n	5 mm
Mounting condition	flush
Assured sensing range	$\leq (0,81 \times S_n)$ mm
Repeatability	$\leq 2\%$ of full scale
Temperature drift	10 %
Hysteresis	$\leq \pm 15\%$, $\leq -25\text{ °C}$ v $\geq +70\text{ °C}$
Ambient temperature	3...15 %
Ambient temperature	-30...+85 °C
Operating voltage	10...65VDC
Residual ripple	$\leq 10\%$ $U_{s\text{}}$
DC rated operational current	≤ 200 mA
No-load current I_0	≤ 20 mA
Residual current	≤ 0.1 mA
Rated insulation voltage	≤ 0.5 kV
Short-circuit protection	yes/ cyclic
Voltage drop at I_n	≤ 1.8 V
Wire breakage / Reverse polarity protection	yes/ complete
Output function	3-wire, NO contact, PNP
Design	threaded barrel, M18 x 1
Dimensions	75 mm
Housing material	metal, CuZn, chrome-plated
Material active area	Plastic, PBT
End cap	Plastic, EPTR
Max. tightening torque housing nut	25 Nm
Connection	cable
Cable quality	5.2 mm, LifYY, PVC, 2 m
Cable cross section	3 x 0.34 mm ²
Vibration resistance	55 Hz (1 mm)
Shock resistance	30 g (11 ms)
Protection class	IP67
Power-on indication	LED green
Switching state	LED yellow

**Inductive sensor
slip monitor
DBI5U-M18E-AP4X2 50/MIN**

Distance D	2 x B
Distance W	3 x Sn
Distance T	3 x B
Distance S	1.5 x B
Distance G	6 x Sn

Diameter of the active area B \varnothing 18 mm



Accessories

Type code	Ident no.	Description	Dimension drawing
QM-18	6945102	Quick-mount bracket with dead-stop; material: Chrome-plated brass Male thread M24 x 1.5. Note: The switching distance of proximity switches can be reduced by the use of quick-mount brackets.	
BST-18B	6947214	Fixing clamp for threaded barrel devices, with dead-stop; material: PA6	
MW-18	6945004	Mounting bracket for threaded barrel devices; material: Stainless steel A2 1.4301 (AISI 304)	
BSS-18	6901320	Mounting bracket for smooth and threaded barrel devices; material: Polypropylene	