

- ATEX category II 3 G, Ex Zone 2
- ATEX category II 3 D, Ex Zone 22
- Threaded barrel, M18 x 1
- Stainless steel, 1.4404
- Front cap made of liquid crystal polymer Vectra
- Factor 1 for all metals
- Resistant to magnetic fields
- For temperatures of -40 °C ... +100 °C
- High protection class IP69K, for harsh environments
- Special double-lip seal
- Protection against all common acid and alkaline cleaning agents
- Laser engraved label, permanently legible
- 3-wire DC, 10...30 VDC
- NO contact, PNP output
- Male M12 x 1

Wiring diagram

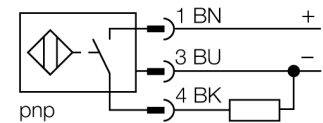

Functional principle

The inductive sensors for the food industry are absolutely tight and resistant to cleaning agents and disinfectants. The requirements of the protection classes IP68 and IP69K are well exceeded by our uprox@+ sensors. The sensors are entirely protected by the LCP front cap and the stainless steel housing.

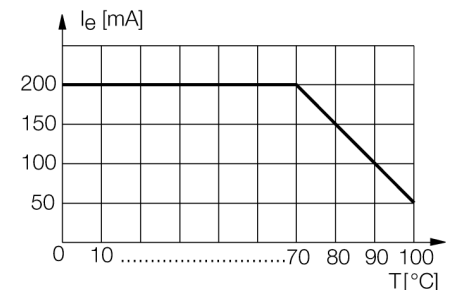

Type code	NI15U-EM18WD-AP6X-H1141/3GD
Ident no.	1634859
Rated operating distance S_n	15 mm
Mounting condition	non-flush
Assured sensing range	≤ (0,81 x S _n) mm
Repeatability	≤ 2 % of full scale
Temperature drift	10 %
Hysteresis	≤ ± 20 %, ≤ -25 °C , ≥ +70 °C
Ambient temperature	3...15 % -40...+100 °C in the explosion hazardous area see instruction leaflet
Operating voltage	10...30VDC
Residual ripple	≤ 10 % U _s
DC rated operational current	≤ 200 mA
No-load current I ₀	≤ 15 mA
Residual current	≤ 0.1 mA
Rated insulation voltage	≤ 0.5 kV
Short-circuit protection	yes/ cyclic
Voltage drop at I ₀	≤ 1.8 V
Wire breakage / Reverse polarity protection	yes/ complete
Output function	3-wire, NO contact, PNP
Protection class	□
Switching frequency	1.5 kHz
Approval acc. to	ATEX test certificate TURCK Ex-13024H X
Device designation	⊕ II 3 G Ex nA IIC T4 Gc/II 3 D Ex tc IIIC T110°C Dc
Design	threaded barrel, M18 x 1
Dimensions	52 mm
Housing material	stainless steel, V4A (1.4404)
Material active area	Plastic, LCP
Connector housing	plastic, PP
Admissible pressure on front cap	≤ 15 bar
Max. tightening torque housing nut	25 Nm
Connection	male, M12 x 1
Vibration resistance	55 Hz (1 mm)
Shock resistance	30 g (11 ms)
Protection class	IP68 / IP69K
MTTF	874 years acc. to SN 29500 (Ed. 99) 40 °C
Switching state	LED yellow

Distance D	72 mm
Distance W	45 mm
Distance T	54 mm
Distance S	27 mm
Distance G	90 mm
Distance N	20 mm

Diameter of the active area B Ø 18 mm

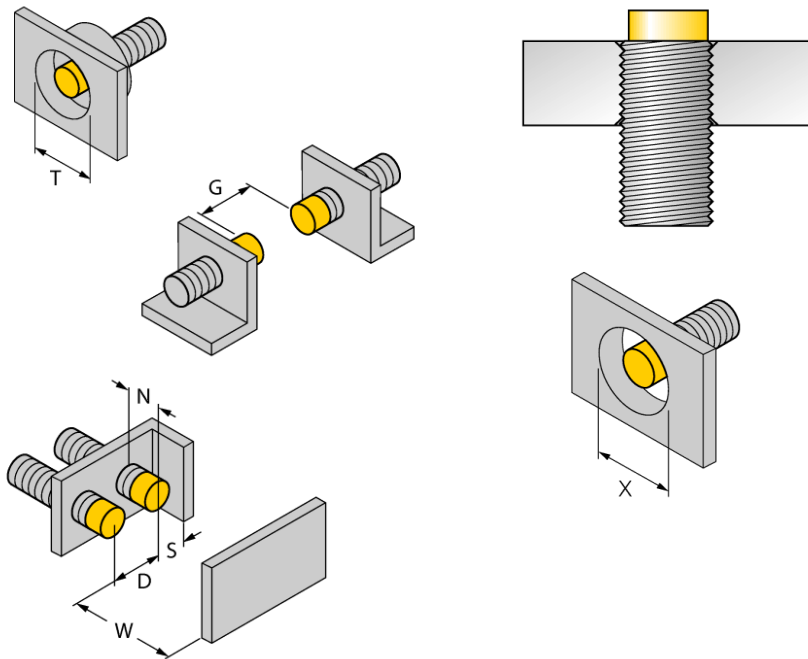

All non-flush mountable *uprox*+ threaded barrel sensors can be screwed to the upper edge of the barrel. Thus safe operation is guaranteed with a reduced switching distance of max. 20 %.

When installed in an aperture plate a distance of X = 70 mm must be observed.

Accessories

Type code	Ident no.	Description	Dimension drawing
MW-18	6945004	Mounting bracket for threaded barrel devices; material: Stainless steel A2 1.4301 (AISI 304)	
BSS-18	6901320	Mounting bracket for smooth and threaded barrel devices; material: Polypropylene	

Wiring accessories

Type code	Ident no.	Description	Dimension drawing
RKCV4T-2/TEL	6626900		

Operating manual

Intended use

This device fulfills the directive 94/9/EC and is suited for use in explosion hazardous areas according to EN60079-0:2012, EN60079-15:2010 and EN60079-31:2009.

In order to ensure correct operation to the intended purpose it is required to observe the national regulations and directives.

For use in explosion hazardous areas conform to classification

II 3 G and II 3 D (Group II, Category 3 G, electrical equipment for gaseous atmospheres and category 3 D, electrical equipment for dust atmospheres).

Marking (see device or technical data sheet)

Ⓔ II 3 G Ex nA IIC T4 Gc acc. to EN 60079-0:2012 and EN 60079-15:2010 and Ⓔ II 3 D Ex tc IIIC T110°C Dc acc. to EN 60079-0:2012 and EN 60079-31:2009

Local admissible ambient temperature

-25...+70 °C

Installation / Commissioning

These devices may only be installed, connected and operated by trained and qualified staff. Qualified staff must have knowledge of protection classes, directives and regulations concerning electrical equipment designed for use in explosion hazardous areas.

Please verify that the classification and the marking on the device comply with the actual application conditions.

Installation and mounting instructions

Avoid static charging of cables and plastic devices. Please only clean the device with a damp cloth. Do not install the device in a dust flow and avoid build-up of dust deposits on the device.

The devices must be protected against strong magnetic fields.

The pin configuration and the electrical specifications can be taken from the device marking or the technical data sheet.

In order to avoid contamination of the device, please remove possible blanking plugs of the cable glands or connectors only shortly before inserting the cable or opening the cable socket.

Special conditions for safe operation

The sensors are equipped with the safety clip SC-M12/3DG to protect against random disconnect.

Do not disconnect the plug-in connection or cable when energised.

Please attach a warning label permanently in an appropriate fashion in close proximity to the plug-in connection with the following inscription:

Nicht unter Spannung trennen / Do not separate when energized.

To comply with the requirements of the low degree of mechanical risk, the sensor must either be installed in the QV40 housing with one side completely overlaying or to install the sensor in the non-flush EM18-housing with the closure cap 18N-PTFE to install. The sensors shall be installed such that they are protected against mechanical energy >4J.

The connectors are fully IP rated only in combination with the O-ring.

Load voltage and operating voltage of this equipment must be provided by power supplies featuring safe isolation (IEC 60 364/ UL 508), which ensures that the rated voltage (24 VDC +20% = 28.8 VDC) of the equipment is not exceeded by more than 40%.

service / maintenance

Repairs are not possible. The approval expires if the device is repaired or modified by a person other than the manufacturer. The most important data from the approval are listed.