

- Threaded barrel, M18 x 1
- Chrome-plated brass
- Factor 1 for all metals
- Protection class IP68
- Magnetic field immune
- High switching distance
- Integrated predamping protection
- Limited metal-free spaces
- DC 4-wire, 10...55 VDC
- Changeover contact, NPN output
- M12 x 1 connector

**Wiring diagram**

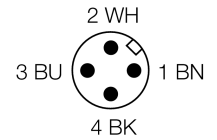
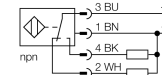

**Functional principle**

Inductive sensors detect metal objects contactless and wear-free. Due to the patented multi-coil system, *Uprox*®+ sensors have distinct advantages compared to conventional sensors. They excel in highest switching distances, maximum flexibility and operational reliability as well as efficient standardization.

<b>Type</b>	NI15U-M18M-VN44X-H1141
<b>Ident-No.</b>	1634883
<b>Rated operating distance Sn</b>	15 mm
Mounting condition	non-flush
Assured sensing range	≤ (0,81 x Sn) mm
Repeatability	≤ 2 %
Temperaturdrift	10 %
	≤ ± 15 %, ≤ -25 °C v ≥ +70 °C
Hysteresis	3...15 %
Ambient temperature	-30...+85 °C
<b>Operating voltage</b>	10...55VDC
Residual ripple	≤ 10 % U <sub>ss</sub>
DC rated operational current	≤ 200 mA
No-load current I <sub>0</sub>	≤ 20 mA
Residual current	≤ 0.1 mA
Rated insulation voltage	≤ 0.5 kV
Short-circuit protection	yes/ cyclic
Voltage drop at I <sub>e</sub>	≤ 1.8 V
Wire breakage / Reverse polarity protection	yes/ complete
Output function	4-wire, changover contact, NPN
Protection class	☐
Switching frequency	1.5 kHz
<b>Design</b>	threaded barrel, M18 x 1
Dimensions	61.5 mm
Housing material	Metal, CuZn, chrome-plated
Material active face	Plastic, LCP
Max. tightening torque housing nut	25 Nm
Connection	male, M12 x 1
Vibration resistance	55 Hz (1 mm)
Shock resistance	30 g (11 ms)
Protection class	IP68
MTTF	874 years acc. to SN 29500 (Ed. 99) 40 °C
<b>Switching state</b>	LED yellow

Mounting instructions	minimum distances
Distance D	72 mm
Distance W	45 mm
Distance T	54 mm
Distance S	27 mm
Distance G	90 mm
Distance N	20 mm

**Diameter of the active area B**                       $\varnothing$  18 mm

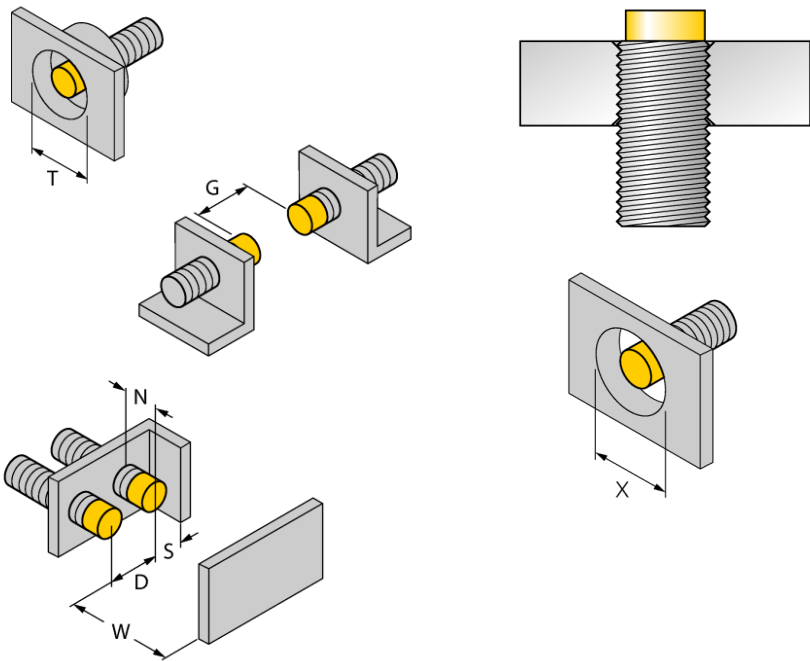

All non-flush mountable *uprox<sup>®</sup>+* threaded barrel sensors can be screwed to the upper edge of the barrel. Thus safe operation is guaranteed with a reduced switching distance of max. 20 %.

When installed in an aperture plate a distance of X = 70 mm must be observed.

**Accessories**

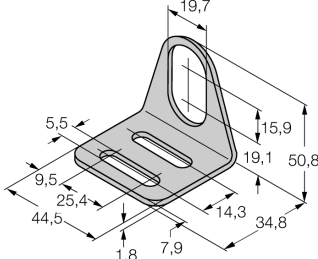
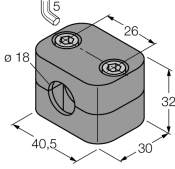
Type code	Ident-No.		Dimension drawing
MW-18	6945004	Mounting bracket for threaded barrel devices; material: Stainless steel A2 1.4301 (AISI 304)	 <p>Technical drawing of a stainless steel mounting bracket for threaded barrel devices. The drawing shows a perspective view with the following dimensions: 19,7 (width of the top loop), 15,9 (height of the loop), 50,8 (total height), 19,1 (width of the base), 34,8 (width of the base), 7,9 (width of the base), 1,8 (thickness of the base), 44,5 (total length), 25,4 (length of the base), 9,5 (width of the base), and 5,5 (width of the base).</p>
BSS-18	6901320	Mounting bracket for smooth and threaded barrel devices; material: Polypropylene	 <p>Technical drawing of a polypropylene mounting bracket for smooth and threaded barrel devices. The drawing shows a perspective view with the following dimensions: 26 (width of the top), 32 (height), 30 (width of the base), 40,5 (total length), and 18 (diameter of the hole, labeled as <math>\varnothing 18</math>).</p>