

- Threaded barrel, M18 x 1
- Stainless steel, 1.4404
- Front cap made of liquid crystal polymer Vectra
- Factor 1 for all metals
- Magnetic field immune
- Extended temperature range
- High protection class IP69K, for harsh environments
- Special double-lip seal
- Protection against all common acid and alkaline cleaning agents
- Laser engraved label, permanently legible
- For the food industry
- DC 4-wire, 10...55 VDC
- Changeover contact, PNP output
- M12 x 1 connector

Wiring diagram

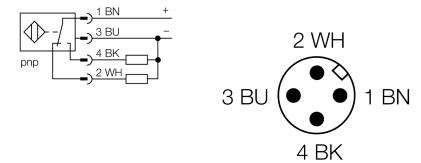

Functional principle

Turck offers the perfect solution for dairies, breweries, for the manufacture of bakery products and frozen food, or for packaging and filling applications in the food industry. The inductive sensors for the food industry are absolutely watertight and resistant to cleaning agents and disinfectants. The requirements of the protection classes IP68 and IP69K are well exceeded by our uprox®+ sensors. The sensors are well protected by an LCP front cap and a stainless steel housing.

Type	NI15U-EM18MWD-VP44X-H1141
Ident-No.	1634898
Rated operating distance Sn	15 mm
Mounting condition	non-flush
Assured sensing range	≤ (0,81 x Sn) mm
Repeatability	≤ 2 %
Temperaturdrift	10 %
Hysteresis	3...15 %
Ambient temperature	-30...+85 °C
Operating voltage	10...55VDC
Residual ripple	≤ 10 % U _{ss}
DC rated operational current	≤ 200 mA
No-load current I ₀	≤ 20 mA
Residual current	≤ 0.1 mA
Rated insulation voltage	≤ 0.5 kV
Short-circuit protection	yes/ cyclic
Voltage drop at I ₀	≤ 1.8 V
Wire breakage / Reverse polarity protection	yes/ complete
Output function	4-wire, changover contact, PNP
Protection class	☑
Switching frequency	1.5 kHz
Design	threaded barrel, M18 x 1
Dimensions	61.5 mm
Housing material	Metal, V4A (1.4404)
Material active face	Plastic, LCP
Connector housing	plastic, PP
Admissible pressure on front cap	≤ 15 bar
Max. tightening torque housing nut	25 Nm
Connection	male, M12 x 1, M12 push-pull compatible
Vibration resistance	55 Hz (1 mm)
Shock resistance	30 g (11 ms)
Protection class	IP68 / IP69K
MTTF	874 years acc. to SN 29500 (Ed. 99) 40 °C
Switching state	LED yellow

Mounting instructions	minimum distances
Distance D	72 mm
Distance W	45 mm
Distance T	54 mm
Distance S	27 mm
Distance G	90 mm
Distance N	20 mm

Diameter of the active area B \varnothing 18 mm

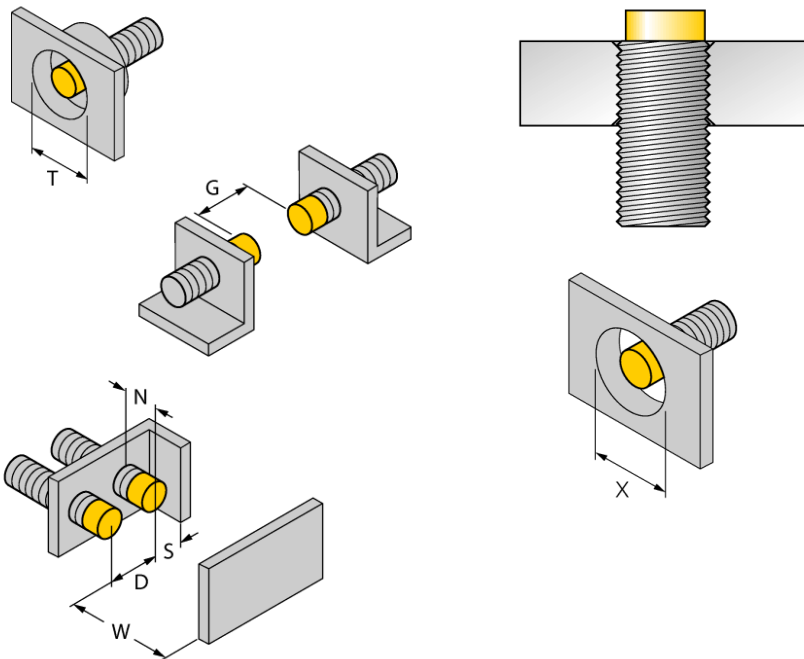

All non-flush mountable *uprox*®+ threaded barrel sensors can be screwed to the upper edge of the barrel. Thus safe operation is guaranteed with a reduced switching distance of max. 20 %.

When installed in an aperture plate a distance of X = 70 mm must be observed.

Accessories

Type code	Ident-No.		Dimension drawing
MW-18	6945004	Mounting bracket for threaded barrel devices; material: Stainless steel A2 1.4301 (AISI 304)	
BSS-18	6901320	Mounting bracket for smooth and threaded barrel devices; material: Polypropylene	