

- Threaded barrel, M30 x 1.5
- Stainless steel, 1.4404
- Front cap made of liquid crystal polymer Vectra
- Factor 1 for all metals
- Resistant to magnetic fields
- For temperatures of -40 °C ... +100 °C
- High protection class IP69K, for harsh environments
- Special double-lip seal
- Protection against all common acid and alkaline cleaning agents
- For the food industry
- 3-wire DC, 10...30 VDC
- NO contact, PNP output
- Terminal chamber

Type code	NI30U-EM30WDTC-AP6X
Ident no.	1634765
Rated operating distance Sn	30 mm
Mounting condition	non-flush
Assured sensing range	≤ (0,81 x Sn) mm
Repeatability	≤ 2 % of full scale
Temperature drift	10 %
	≤ ± 20 %, ≤ -25 °C , ≥ +70 °C
Hysteresis	3...15 %
Ambient temperature	-40...+100 °C
Operating voltage	10...30VDC
Residual ripple	≤ 10 % U _{ss}
DC rated operational current	≤ 200 mA
No-load current I ₀	≤ 15 mA
Residual current	≤ 0.1 mA
Rated insulation voltage	≤ 0.5 kV
Short-circuit protection	yes/ cyclic
Voltage drop at I ₀	≤ 1.8 V
Wire breakage / Reverse polarity protection	yes/ complete
Output function	3-wire, NO contact, PNP
Protection class	☐
Switching frequency	0.5 kHz
Design	threaded barrel, M30 x 1.5
Dimensions	95 mm
Housing material	stainless steel, V4A (1.4404)
Terminal chamber cover material	plastic, Ultem
Terminal chamber housing material	plastic, LCP-GF30
Material active area	Plastic, LCP
Admissible pressure on front cap	≤ 10 bar
Max. tightening torque housing nut	75 Nm
Connection	terminal chamber, Removable cage clamp terminals suited for M16 x 1.5 cable glands
Clamping ability	≤ 1.5 mm ²
Vibration resistance	55 Hz (1 mm)
Shock resistance	30 g (11 ms)
Protection class	IP68 / IP69K
MTTF	874 years acc. to SN 29500 (Ed. 99) 40 °C
Switching state	LED yellow

Wiring diagram

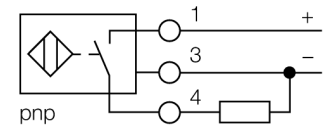

Functional principle

uprox®+ sensors from TURCK are the perfect solution for dairies, breweries, industrial bakeries, frozen food, packaging and filling applications. They are absolutely tight and resistant to cleaning agents and disinfectants and well exceed the requirements of the protection classes IP68 and IP69K thanks to the LCP front cap and the stainless steel housing.

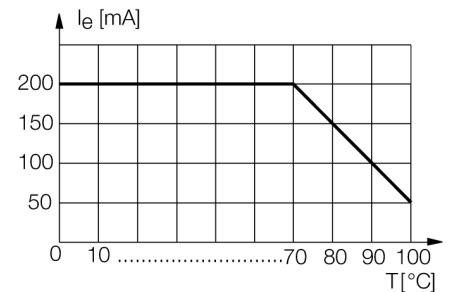

Distance D	135 mm
Distance W	90 mm
Distance T	90 mm
Distance S	45 mm
Distance G	180 mm
Distance N	30 mm

Diameter of the active area B Ø 30 mm

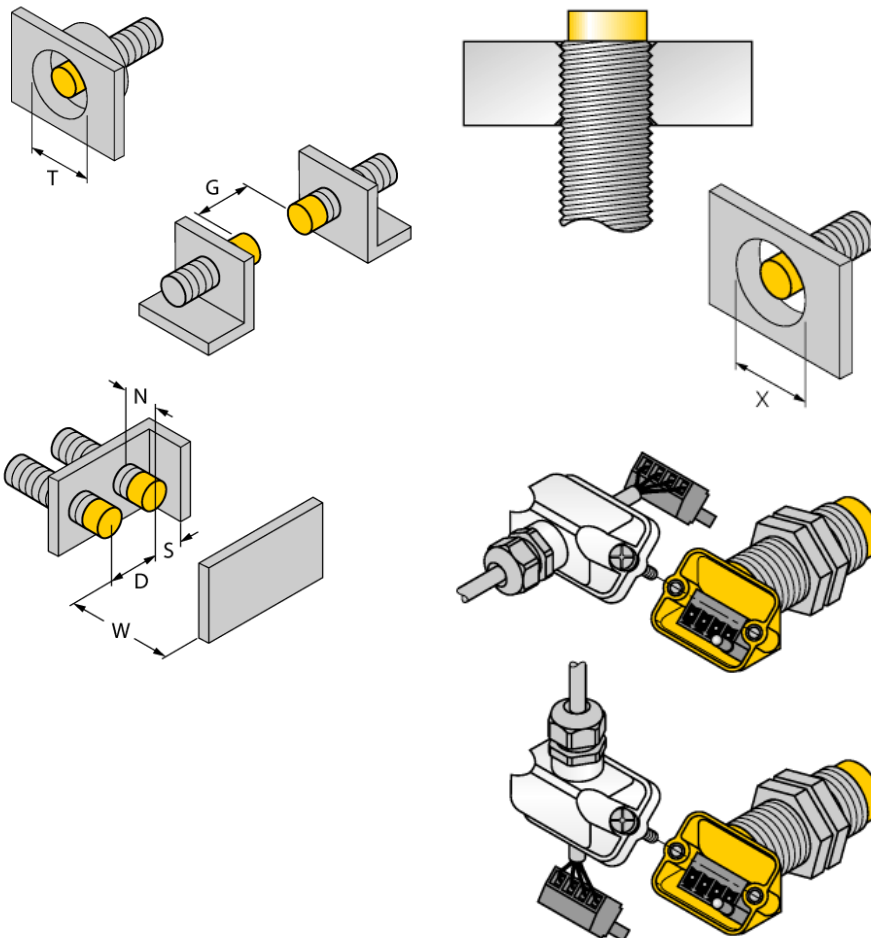

All non-flush mountable uprox®+ threaded barrel sensors can be screwed to the upper edge of the barrel. Thus safe operation is guaranteed with a reduced switching distance of max. 20 %.

When installed in an aperture plate a clearance of X = 50 mm must be observed.

The innovative terminal chamber concept enables simple and comfortable connection of the sensor. Straight as well as angled cable outlets are available and the removable terminal strip guarantees easy wiring.

Accessories

Type code	Ident no.	Description	Dimension drawing
M16X1,5 PVDF CABLE GLAND	1634759	Cable glands M16 x 1.5, material PVDF	
MW-30	6945005	Mounting bracket for threaded barrel devices; material: Stainless steel A2 1.4301 (AISI 304)	
BSS-30	6901319	Mounting bracket for smooth and threaded barrel devices; material: Polypropylene	