

Capacitive sensor
BC3-M12-AP6X/S90/3GD

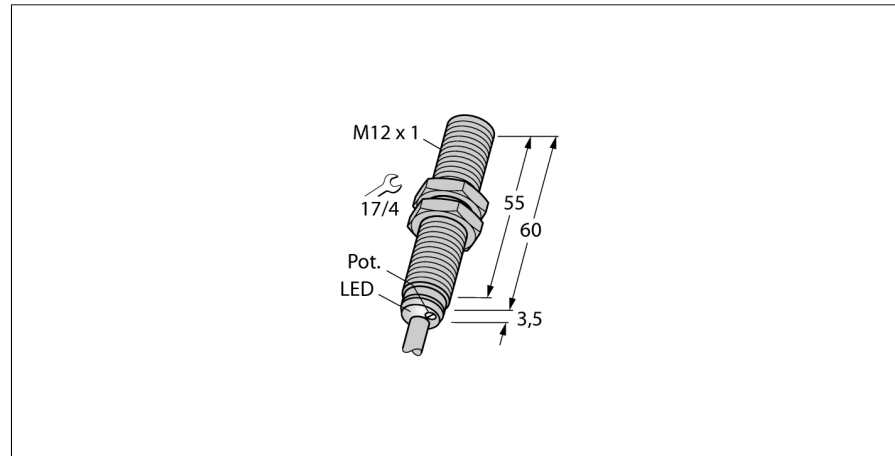

- ATEX category II 3 G, Ex Zone 2
- ATEX category II 3 D, Ex Zone 22
- Threaded barrel, M12 x 1
- Chrome-plated brass
- Fine adjustment via potentiometer
- DC 3-wire, 10...30 VDC
- NO contact, PNP output
- Cable connection

Wiring diagram

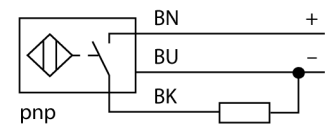

Functional principle

Capacitive proximity switches are designed for non-contact and wear-free detection of electrically conductive as well as non-conductive metal objects.

Type code	BC3-M12-AP6X/S90/3GD
Ident no.	2601003
Rated switching distance (flush)	3 mm
Rated switching distance (non-flush)	3 mm
Assured sensing range	≤ (0.72 x Sn) mm
Hysteresis	2...20 %
Temperature drift	type ≤ ± 20 %
Repeatability	≤ 2 % of full scale
Ambient temperature	-25...+70 °C in the explosion hazardous area see instruction leaflet
Operating voltage	10...30VDC
Residual ripple	≤ 10 % U _{in}
DC rated operational current	≤ 200 mA
No-load current I ₀	≤ 15 mA
Residual current	≤ 0.1 mA
Switching frequency	0.1 kHz
Rated insulation voltage	≤ 0.5 kV
Output function	3-wire, NO contact, PNP
Short-circuit protection	yes/ cyclic
Voltage drop at I ₀	≤ 1.8 V
Wire breakage / Reverse polarity protection	yes/ complete
Approval acc. to	ATEX declaration of conformity TURCK Ex-03025H X
Device designation	Ex II 3 G Ex nA IIC T5 Gc / II 3 D Ex t IIIC T91 °C Dc
Warning	protect against mechanical damage
Design	threaded barrel, M12 x 1
Dimensions	63.5 mm
Housing material	metal, CuZn, chrome-plated
Material active area	Plastic, ABS, yellow
Admissible pressure on front cap	≤ 5 bar
Max. tightening torque housing nut	10 Nm
Connection	cable
Cable quality	Ø 4, LiYY-11Y, PUR, 2 m
Cable cross section	3 x 0.25 mm ²
Vibration resistance	55 Hz (1 mm)
Shock resistance	30 g (11 ms)
Protection class	IP67
MTTF	1080 years acc. to SN 29500 (Ed. 99) 40 °C
Switching state	LED yellow

**Capacitive sensor
BC3-M12-AP6X/S90/3GD**

Mounting instructions / Description	minimum distances
Distance D	24 mm
Distance W	9 mm
Distance S	18 mm
Distance G	18 mm

Diameter of the active area B \varnothing 12 mm

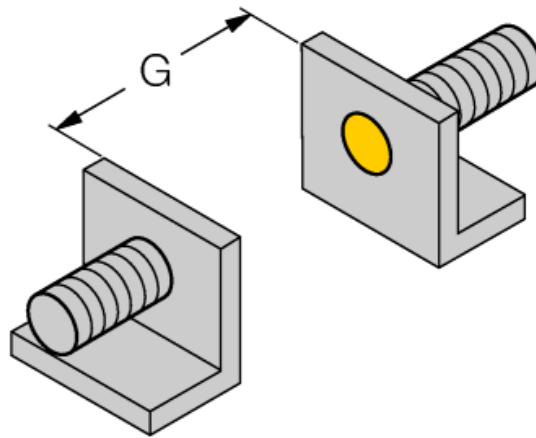

The given minimum distances have been checked in compliance with the standard switching distance. Should the sensitivity of the sensors be changed via potentiometer, the data sheet specifications no longer apply.



**Capacitive sensor
BC3-M12-AP6X/S90/3GD**

TURCK

Industrial
Automation

Accessories

Type code	Ident no.	Description	Dimension drawing
MAP-M12-PP	6950016	Mounting adapter; material: Polypropylene; sensor replacement with filled container possible (adapter remains in container during sensor replacement)	
MAP-M12-PVDF	6950017	Mounting adapter; material: Polyvinylidenflourid; sensor can be replaced with filled container (adapter remains in container during replacement)	
BST-12B	6947212	Fixing clamp for threaded barrel devices, with dead-stop; material: PA6	

Capacitive sensor

BC3-M12-AP6X/S90/3GD

TURCK

Industrial
Automation

Operating manual

Intended use

This device fulfills the directive 94/9/EC and is suited for use in explosion hazardous areas according to EN60079-0:2009, EN60079-15:2010 and EN60079-31:2009.

In order to ensure correct operation to the intended purpose it is required to observe the national regulations and directives.

For use in explosion hazardous areas conform to classification

II 3 G and II 3 D (Group II, Category 3 G, electrical equipment for gaseous atmospheres and category 3 D, electrical equipment for dust atmospheres).

Marking (see device or technical data sheet)

Ex II 3 G and Ex nA IIC T5 Gc acc. to EN 60079-0:2009 and EN 60079-15:2010 and Ex II 3 D Ex t IIIC T91°C Dc acc. to EN 60079-0:2009 and EN 60079-31:2009

Local admissible ambient temperature

-25...+70 °C

Installation / Commissioning

These devices may only be installed, connected and operated by trained and qualified staff. Qualified staff must have knowledge of protection classes, directives and regulations concerning electrical equipment designed for use in explosion hazardous areas.

Please verify that the classification and the marking on the device comply with the actual application conditions.

Installation and mounting instructions

Avoid static charging of cables and plastic devices. Please only clean the device with a damp cloth. Do not install the device in a dust flow and avoid build-up of dust deposits on the device.

If the devices and the cable could be subject to mechanical damage, they must be protected accordingly. They must also be shielded against strong electro-magnetic fields.

The pin configuration and the electrical specifications can be taken from the device marking or the technical data sheet.

In order to avoid contamination of the device, please remove possible blanking plugs of the cable glands or connectors only shortly before inserting the cable or opening the cable socket.

Special conditions for safe operation

Devices with terminal chamber (cable glands) have a weaker strain relief. Sufficient strain relief must be ensured or the cable must be stationary-mounted.

For devices with M12 connectors please use the supplied safety clip SC-M12/3GD.

Do not disconnect the plug-in connection or cable when energised.

Please attach a warning label permanently in an appropriate fashion in close proximity to the plug-in connection with the following inscription: Nicht unter Spannung trennen / Do not separate when energized.

The device must be protected against any kind of mechanical damage and degrading UV-radiation. On selecting the approval-relevant accessories, always ensure that they are installed conform to the application.

Load voltage and operating voltage of this equipment must be provided by power supplies featuring safe isolation (IEC 60 364/ UL 508), which ensures that the rated voltage (24 VDC +20% = 28.8 VDC) of the equipment is not exceeded by more than 40%.

service / maintenance

Repairs are not possible. The approval expires if the device is repaired or modified by a person other than the manufacturer. The most important data from the approval are listed.