

# Capacitive sensor BC10-QF5,5-RP6X2

**TURCK**

Industrial  
Automation

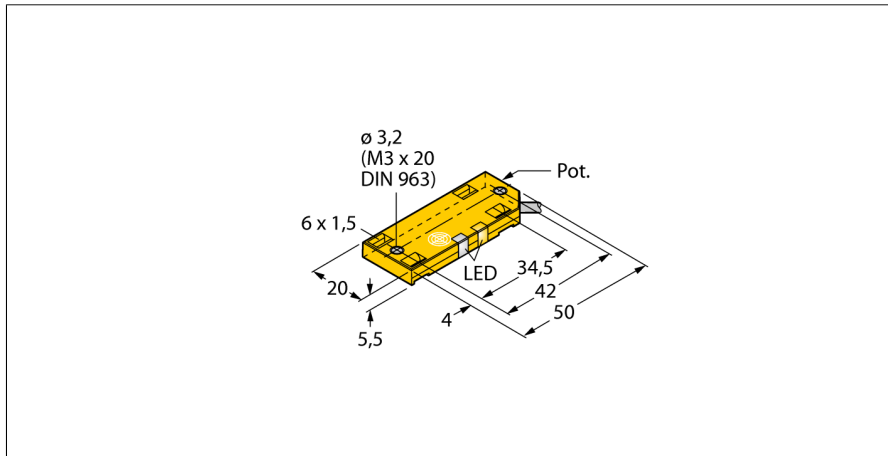

- Rectangular, height 5.5 mm
- Active face on top
- Plastic, PP
- Fine adjustment via potentiometer
- DC 3-wire, 10...30 VDC
- NC contact, PNP output
- Cable connection

## Wiring diagram

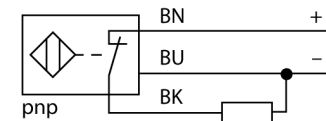

## Functional principle

Capacitive proximity switches are designed for non-contact and wear-free detection of electrically conductive as well as non-conductive metal objects.

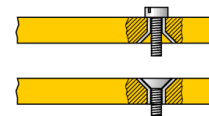
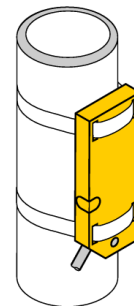

<b>Type code</b>	BC10-QF5,5-RP6X2
Ident no.	2620126
<b>Rated switching distance (flush)</b>	10 mm
Rated switching distance (non-flush)	10 mm
Assured sensing range	≤ (0.72 x Sn) mm
Hysteresis	2...20 %
Temperature drift	type ≤ ± 20 %
Repeatability	≤ 2 % of full scale
Ambient temperature	-25...+70 °C
<b>Operating voltage</b>	10...30VDC
Residual ripple	≤ 10 % U <sub>in</sub>
DC rated operational current	≤ 200 mA
No-load current I <sub>0</sub>	≤ 15 mA
Residual current	≤ 0.1 mA
Switching frequency	0.1 kHz
Rated insulation voltage	≤ 0.5 kV
Output function	3-wire, NC contact, PNP
Short-circuit protection	yes/ cyclic
Voltage drop at I <sub>0</sub>	≤ 1.8 V
Wire breakage / Reverse polarity protection	yes/ complete
<b>Design</b>	rectangular, QF5.5
Dimensions	54 x 20.3 x 5.5 mm
Housing material	plastic, PP
Material active area	Plastic, PP
Connection	cable
Cable quality	Ø 3, LiYY-11Y, PUR, 2 m
Cable cross section	3 x 0.14 mm <sup>2</sup>
Vibration resistance	55 Hz (1 mm)
Shock resistance	30 g (11 ms)
Protection class	IP67
MTTF	1080 years acc. to SN 29500 (Ed. 99) 40 °C
<b>Power-on indication</b>	LED green
Switching state	LED yellow
Included in scope of supply	2 retaining straps

**Capacitive sensor  
BC10-QF5,5-RP6X2**

Distance D	40 mm
Distance W	30 mm
Distance S	30 mm
Distance G	60 mm

---

Diameter of the active area B                      Ø 20 mm

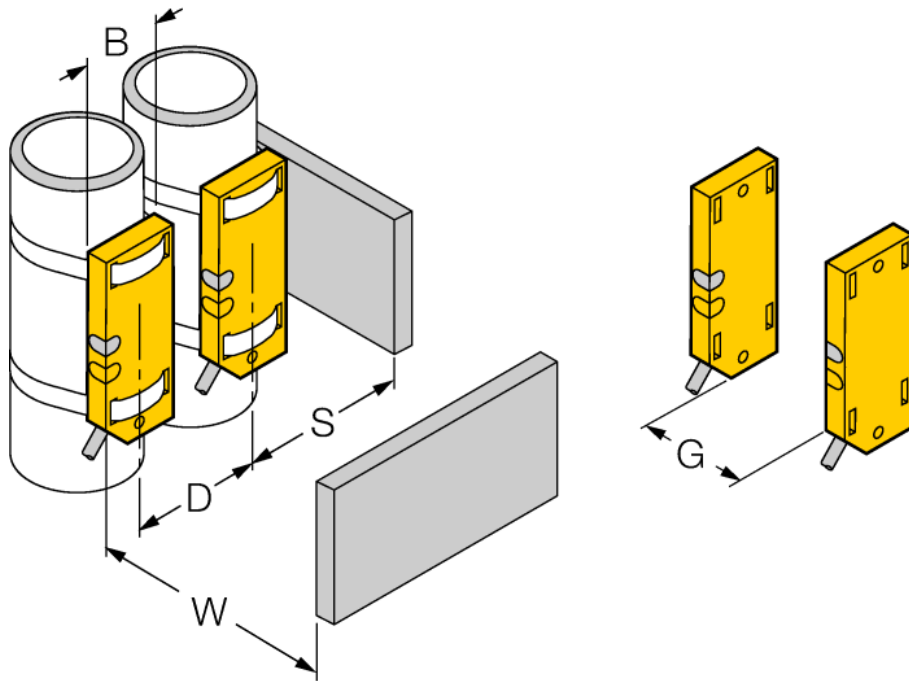

The given minimum distances have been checked against the standard switching distance. Should the sensitivity of the sensors be changed via potentiometer, the data sheet specifications no longer apply.