

Capacitive sensor
BC5-QF5,5-AP6X2-2-RS4/S250/3G

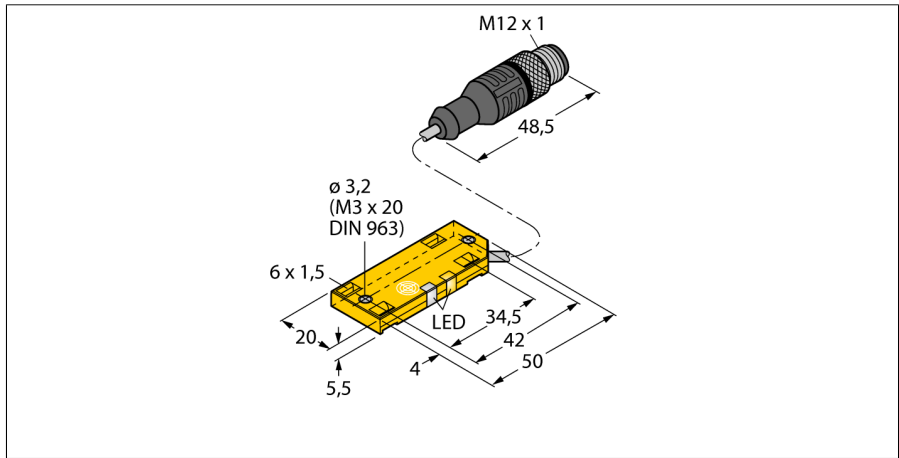

- Rectangular, height 5.5 mm
- Active face on top
- Plastic, PP
- Fixed settings
- DC 3-wire, 10...30 VDC
- NO contact, PNP output
- M12 x 1 connector

Wiring diagram

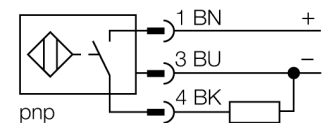

Type code	BC5-QF5,5-AP6X2-2-RS4/S250/3G
Ident no.	2620135
Rated switching distance (flush)	5 mm
Rated switching distance (non-flush)	5 mm
Assured sensing range	≤ (0.72 x S _n) mm
Hysteresis	2...20 %
Temperature drift	type ≤ ± 20 %
Repeatability	≤ 2 % of full scale
Ambient temperature	-25...+70 °C
Operating voltage	10...30VDC
Residual ripple	≤ 10 % U _{is}
DC rated operational current	≤ 200 mA
No-load current I ₀	≤ 15 mA
Residual current	≤ 0.1 mA
Switching frequency	0.1 kHz
Rated insulation voltage	≤ 0.5 kV
Output function	3-wire, NO contact, PNP
Short-circuit protection	yes/ cyclic
Voltage drop at I ₀	≤ 1.8 V
Wire breakage / Reverse polarity protection	yes/ complete
Design	rectangular, QF5.5
Dimensions	54 x 20.3 x 5.5 mm
Housing material	plastic, PP
Material active area	Plastic, PP
Connection	male, M12 x 1
Cable quality	Ø 3, Lif9Y-11Y, PUR, 2 m
Cable cross section	3 x 0.14 mm ²
Vibration resistance	55 Hz (1 mm)
Shock resistance	30 g (11 ms)
Protection class	IP67
MTTF	1080 years acc. to SN 29500 (Ed. 99) 40 °C
Power-on indication	LED green
Switching state	LED yellow
Included in scope of supply	2 retaining straps

Functional principle

Capacitive proximity switches are designed for non-contact and wear-free detection of electrically conductive as well as non-conductive metal objects.

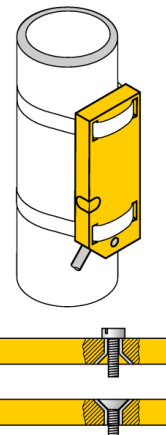

Capacitive sensor
BC5-QF5,5-AP6X2-2-RS4/S250/3G

Distance D	40 mm
Distance W	30 mm
Distance S	30 mm
Distance G	60 mm

Diameter of the active area B \varnothing 20 mm

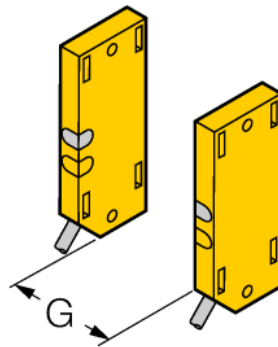
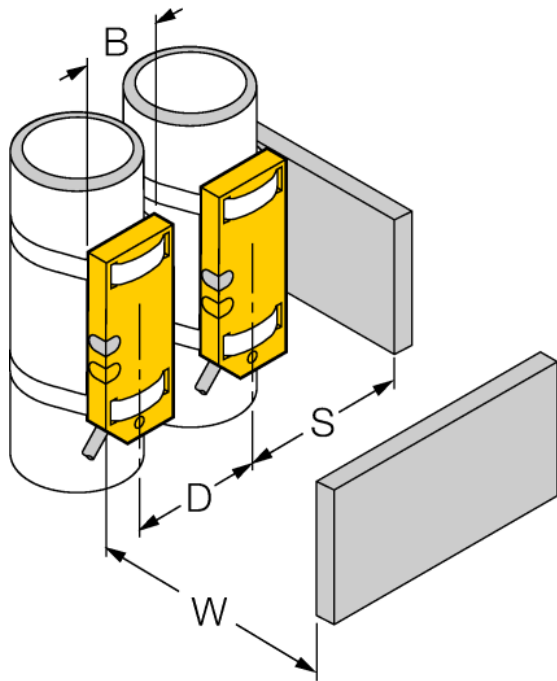

The given minimum distances have been checked against the standard switching distance. Should the sensitivity of the sensors be changed via potentiometer, the data sheet specifications no longer apply.