

**Capacitive sensor**  
**BC10-P30SR-VP4X2/3GD**

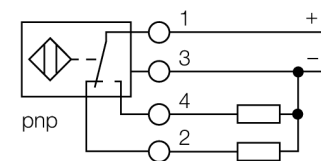

- ATEX category II 3 G, Ex Zone 2
- ATEX category II 3 D, Ex Zone 22
- Threaded barrel, M30 x 1.5
- Plastic, PA12-GF30
- Fine adjustment via potentiometer
- DC 4-wire, 10...65 VDC
- Changeover contact, PNP output
- Terminal chamber

**Wiring diagram**



**Functional principle**

Capacitive proximity switches are designed for non-contact and wear-free detection of electrically conductive as well as non-conductive metal objects.

<b>Type code</b>	BC10-P30SR-VP4X2/3GD
Ident no.	2505006
<b>Rated switching distance (flush)</b>	10 mm
Rated switching distance (non-flush)	15 mm
Assured sensing range	≤ (0.72 x S <sub>n</sub> ) mm
Hysteresis	2...20 %
Temperature drift	type ≤ ± 20 %
Repeatability	≤ 2 % of full scale
Ambient temperature	-25...+70 °C
<b>Operating voltage</b>	10...65VDC
Residual ripple	≤ 10 % U <sub>s</sub>
DC rated operational current	≤ 200 mA
No-load current I <sub>0</sub>	≤ 15 mA
Residual current	≤ 0.1 mA
Switching frequency	0.1 kHz
Rated insulation voltage	≤ 0.5 kV
Output function	4-wire, changover contact, PNP
Short-circuit protection	yes/ cyclic
Voltage drop at I <sub>s</sub>	≤ 1.8 V
Wire breakage / Reverse polarity protection	yes/ complete
<b>Approval acc. to</b>	ATEX declaration of conformity 3146M
Device designation	Ⓢ II 3 G EEx nA II T4 X / II3 D IP67 T 90 °C
Warning	Use ATEX approved cable glands only.
<b>Design</b>	threaded barrel, M30 x 1.5
Housing material	silicone, PA
Material active area	Plastic, PA12-GF30, yellow
Admissible pressure on front cap	≤ 3 bar
Max. tightening torque housing nut	5 Nm
Connection	terminal chamber
Vibration resistance	55 Hz (1 mm)
Shock resistance	30 g (11 ms)
Protection class	IP67
MTTF	1080 years acc. to SN 29500 (Ed. 99) 40 °C
<b>Switching state</b>	LED

# Capacitive sensor BC10-P30SR-VP4X2/3GD

**TURCK**

Industrial  
Automation

Mounting instructions / Description	minimum distances
Distance D	60 mm
Distance W	30 mm
Distance S	45 mm
Distance G	60 mm

Diameter of the active area B       $\varnothing$  30 mm



The given minimum distances have been checked in compliance with the standard switching distance. Should the sensitivity of the sensors be changed via potentiometer, the data sheet specifications no longer apply.

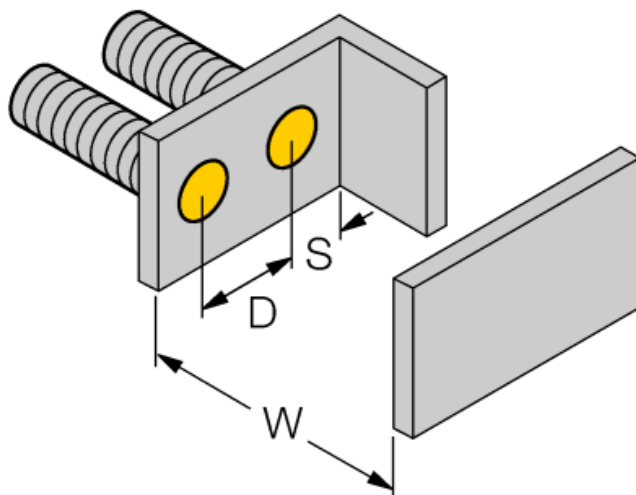

# Capacitive sensor

## BC10-P30SR-VP4X2/3GD

**TURCK**

Industrial  
Automation

### Operating manual

#### Intended use

This device fulfils the directive 94/9/EC and is suited for use in explosion hazardous areas according to EN50014, EN50020 and EN50281-1-1. In order to ensure correct operation to the intended purpose it is required to observe the national regulations and directives.

#### For use in explosion hazardous areas conform to classification

II 3 G and II 3 D (Group II, Category 3 G, electrical equipment for gaseous atmospheres and category 3 D, electrical equipment for dust atmospheres).

#### Marking (see device or technical data sheet)

⊕ II 3 G and EEx nA II T4 X "non sparking" acc.to EN50021 and ⊕ II 3 D IP67 T 95°C acc.to EN50281-1-1

#### Local admissible ambient temperature

-25...+70 °C

#### Installation / Commissioning

These devices may only be installed, connected and operated by trained and qualified staff. Qualified staff must have knowledge of protection classes, directives and regulations concerning electrical equipment designed for use in explosion hazardous areas. Please verify that the classification and the marking on the device comply with the actual application conditions.

#### Installation and mounting instructions

Avoid static charging of cables and plastic devices. Please only clean the device with a damp cloth. Do not install the device in a dust flow and avoid build-up of dust deposits on the device.

If the devices and the cable could be subject to mechanical damage, they must be protected accordingly. They must also be shielded against strong electro-magnetic fields.

The pin configuration and the electrical specifications can be taken from the device marking or the technical data sheet.

In order to avoid contamination of the device, please remove possible blanking plugs of the cable glands or connectors only shortly before inserting the cable or opening the cable socket.

#### Special conditions for safe operation

Devices with terminal chamber (cable glands) have a weaker strain relief. Sufficient strain relief must be ensured or the cable must be stationary-mounted.

For devices with M12 connectors please use the supplied safety clip SC-M12/3GD.

Do not disconnect the plug-in connection or cable when energised.

Please attach a warning label permanently in an appropriate fashion in close proximity to the plug-in connection with the following inscription:

Nicht unter Spannung trennen / Do not separate when energized.

#### service / maintenance

Repairs are not possible. The approval expires if the device is repaired or modified by a person other than the manufacturer. The most important data from the approval are listed.