

Magnetic field sensor
magnet-inductive proximity sensor
BIM-PST-AP6X-V1131/S235

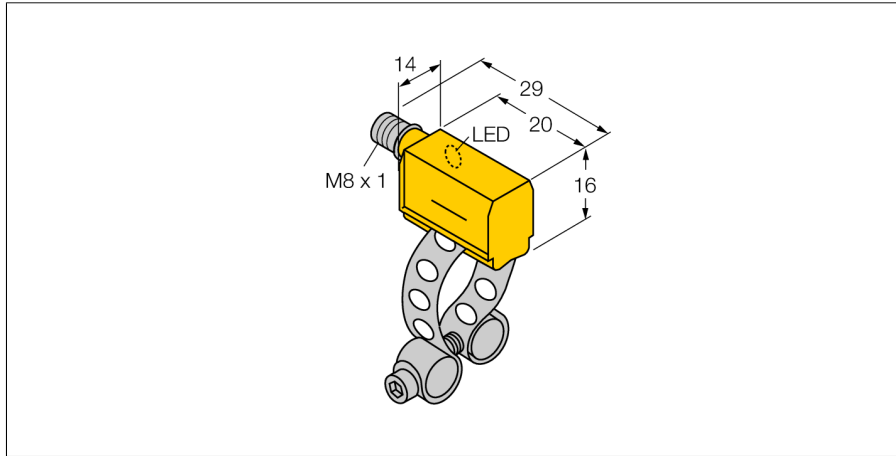

- Rectangular, height 16 mm
- Front active face
- Plastic, PA12-GF30
- Increased sensitivity
- DC 3-wire, 10...30 VDC
- NO contact, PNP output
- Male connector, M8 x 1

Wiring diagram

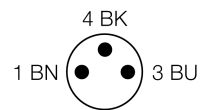
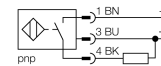

Type code	BIM-PST-AP6X-V1131/S235
Ident no.	4625020
Pass speed	≤ 10 m/s
Repeatability	≥ ± 0.1 mm
Temperature drift	≤ 0.1 mm
Hysteresis	≤ 1 mm
Ambient temperature	-25...+70 °C
Operating voltage	10...30VDC
Residual ripple	≤ 10 % U _s
DC rated operational current	≤ 200 mA
No-load current I ₀	≤ 15 mA
Residual current	≤ 0.1 mA
Rated insulation voltage	≤ 0.5 kV
Short-circuit protection	yes/ cyclic
Voltage drop at I ₀	≤ 1.8 V
Wire breakage / Reverse polarity protection	yes/ complete
Output function	3-wire, NO contact, PNP
Switching frequency	1 kHz
Design	rectangular, PST
Dimensions	23 x 14 x 16 mm
Housing material	plastic, PA
Material active area	Plastic, PA
Connection	male, M8 x 1
Vibration resistance	55 Hz (1 mm)
Shock resistance	30 g (11 ms)
Protection class	IP67
MTTF	2283 years acc. to SN 29500 (Ed. 99) 40 °C
Mounting on the following profiles	.
Cylindrical design	○
Switching state	LED yellow
Included in scope of supply	KLP25

Functional principle

Magnetic field sensors are activated by magnetic fields and are especially suited for piston position detection in pneumatic cylinders. Based on the fact that magnetic fields can permeate non-magnetizable metals, it is possible to detect a permanent magnet attached to the piston through the aluminium wall of the cylinder.

Magnetic field sensor
magnet-inductive proximity sensor
BIM-PST-AP6X-V1131/S235

Accessories

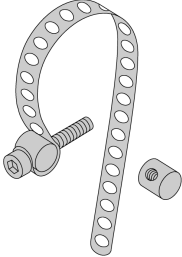
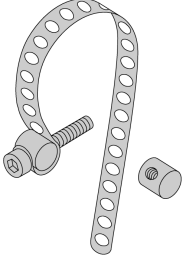
Type code	Ident no.	Description	Dimension drawing
KLP 25 MONTAGESET	69653	Mounting on ○ cylinders; cylinder diameter 8...25 mm (material: Metal CuZn), 2 tie bolts (material: Metal CuZn), cylinder screw M3 x 20	
KLP 80-VA	69654	Mounting on ○ cylinders; cylinder diameter 25...80 mm (material: Metal A2 1.4301 (AISI 304), 2 tie bolts (material: Metal CuZn, alternatively metal A2 1.4301 / AISI 304) cylinder screw M3 x 20; (DIN 912-A20)	
KLP 200-VA	6965302	Mounting on ○ cylinders; cylinder diameter 80...200 mm (material: Metal A2 1.4301 (AISI 304), 2 tie bolts (material: Metal CuZn, alternatively metal A2 1.4301 / AISI 304) cylinder screw M3 x 20; (DIN 912-A20)	