

**Magnetic field sensor
for pneumatic cylinders
BIM-UNR-AN6X-0,3-PSG3M**

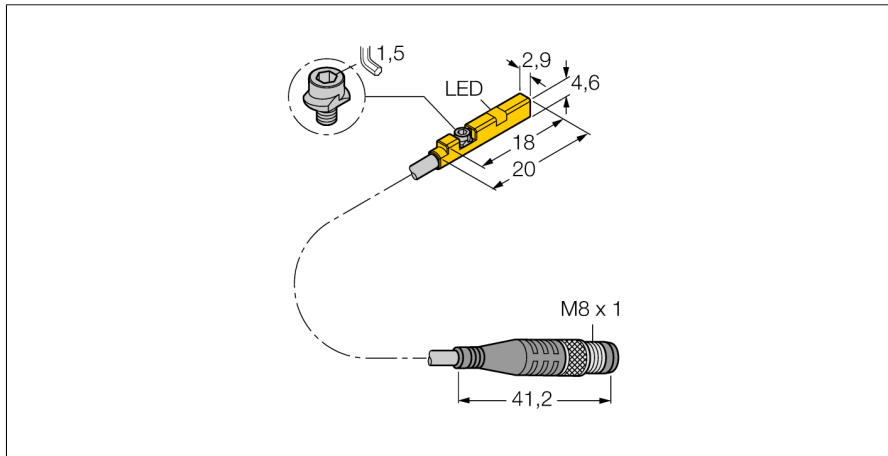

- For C-groove cylinders without mounting accessories
- Optional accessories for mounting on other cylindrical housings.
- One-hand mounting possible
- Stable mounting
- Magneto-resistive sensor
- DC 3-wire, 10...30 VDC
- NO contact, NPN output
- Pigtail with male end, M8 x 1

Wiring diagram

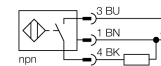

Functional principle

Magnetic field sensors are activated by magnetic fields. They are applied to detect the position of pneumatic cylinders. Magnetic fields can permeate non-magnetizable metals. A permanent magnet attached to the piston is thus detected through the aluminium wall of the cylinder.

Type code	BIM-UNR-AN6X-0,3-PSG3M
Ident no.	4586839
Pass speed	≤ 3 m/s
Repeatability	≥ ± 0.1 mm
Temperature drift	≤ 0.1 mm
Hysteresis	≤ 1 mm
Ambient temperature	-25...+70 °C
Operating voltage	10...30VDC
Residual ripple	≤ 10 % U _s
DC rated operational current	≤ 100 mA
No-load current I₀	≤ 15 mA
Residual current	≤ 0.1 mA
Rated insulation voltage	≤ 0.5 kV
Short-circuit protection	yes/ cyclic
Voltage drop at I₀	≤ 1.8 V
Wire breakage / Reverse polarity protection	yes/ complete
Output function	3-wire, NO contact, NPN
Switching frequency	0.3 kHz
Design	rectangular, UNR
Dimensions	18 x 2.9 x 4.6 mm
Housing material	plastic, PP
Material active area	Plastic, PP
Tightening torque fixing screw	0.2 Nm
Connection	cable with connector, M8 x 1
Cable quality	2 mm, grey, Lif9Y-11Y, PUR, 0.3 m
Cable cross section	3 x 0.08 mm ²
Litz wire	40x0.05mm ²
Vibration resistance	55 Hz (1 mm)
Shock resistance	30 g (11 ms)
Protection class	IP67
MTTF	2283 years acc. to SN 29500 (Ed. 99) 40 °C
Mounting on the following profiles	.
Cylindrical design	
Switching state	LED yellow
Included in scope of supply	cable clip

**Magnetic field sensor
for pneumatic cylinders
BIM-UNR-AN6X-0,3-PSG3M**

TURCK

Industrial
Automation

Mounting instructions / Description

mounting instructions

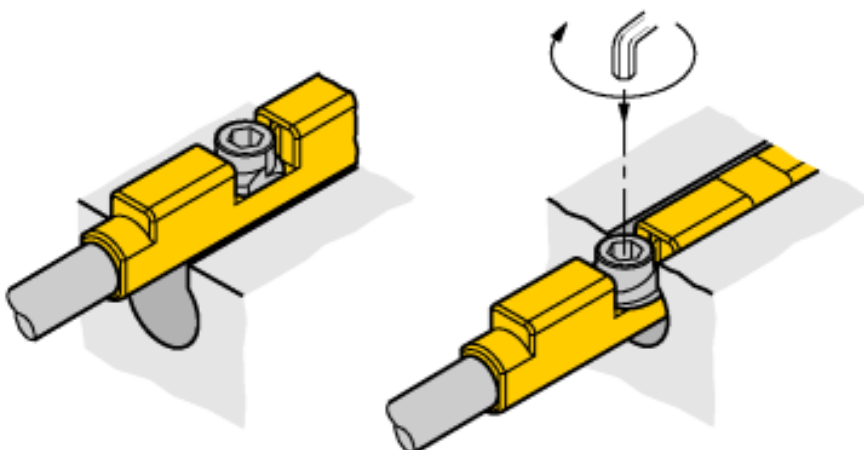
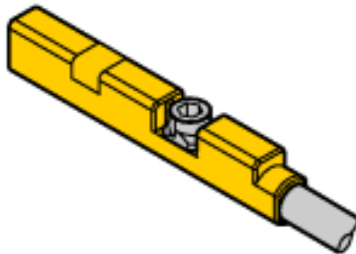
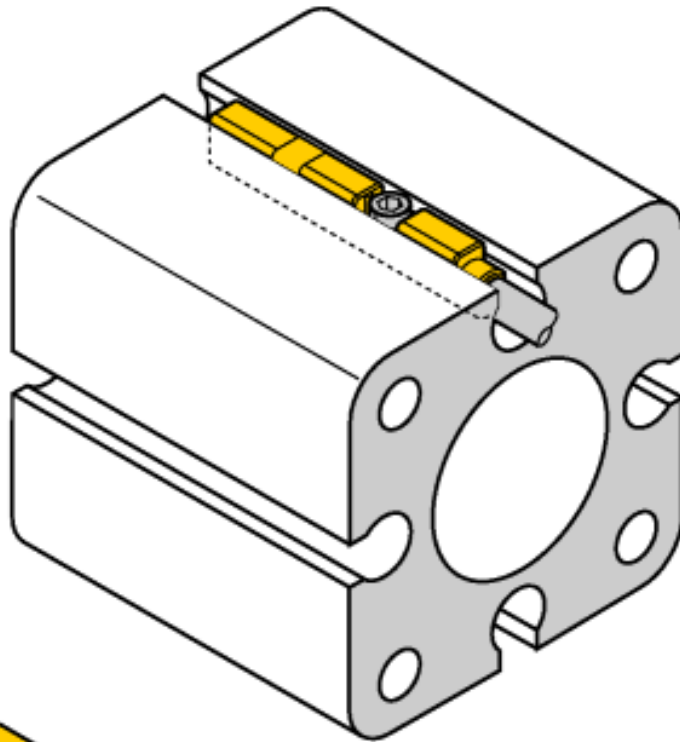

The sensor is mounted in the groove from above. Mount the sensors as follows using the patented wing screw: The wing screw features a left-hand female thread. Two small plastic lips keep the screw in position, ready-to-install. Turn the screw clockwise. The screw moves out of the thread and hits the upper grooves with the wings. The sensor is thus pressed down and locked. Use a 1.5 mm Allen key to fasten the screw with a quarter turn. A fixing torque of 0.2 Nm is sufficient for safe mounting without damaging the cylinder. Cable clips are included in the scope of delivery. They enable smooth cable routing in the groove. Mounting accessories for other cylinder sizes have to be ordered separately.