

**Magnetic field sensor
for pneumatic cylinders
BIM-UNT-AP6X/3GD**

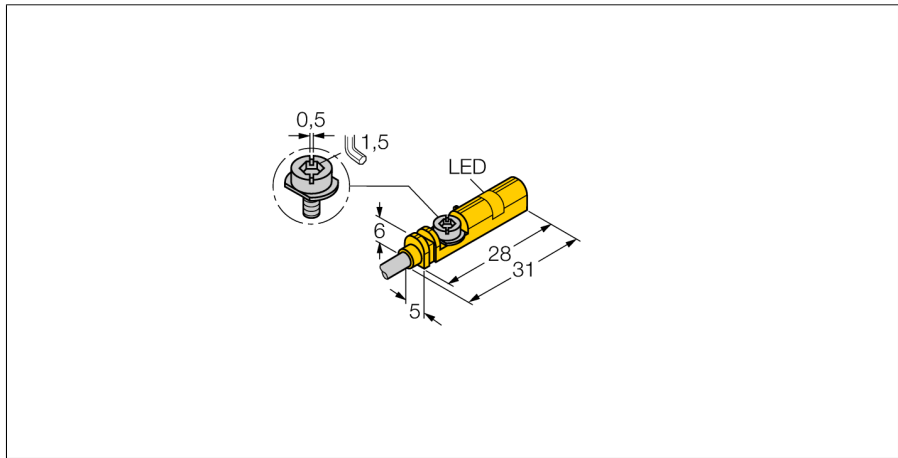

- ATEX category II 3 G, Ex Zone 2
- ATEX category II 3 D, Ex Zone 22
- For T-groove cylinders without mounting accessories
- Optional accessories for mounting on other cylindrical housings.
- One-hand mounting possible
- Fine adjustment tool and stopper directly mountable on the sensor
- Stable mounting
- Magneto-resistive sensor
- DC 3-wire, 10...30 VDC
- NO contact, PNP output
- Cable connection

Type code	BIM-UNT-AP6X/3GD
Ident no.	4685736
Pass speed	≤ 10 m/s
Repeatability	≥ ± 0.1 mm
Temperature drift	≤ 0.1 mm
Hysteresis	≤ 1 mm
Ambient temperature	-25...+70 °C in the explosion hazardous area see instruction leaflet
Operating voltage	10...30VDC
Residual ripple	≤ 10 % U _{ss}
DC rated operational current	≤ 150 mA
No-load current I ₀	≤ 15 mA
Residual current	≤ 0.1 mA
Rated insulation voltage	≤ 0.5 kV
Short-circuit protection	yes/ cyclic
Voltage drop at I _n	≤ 1.8 V
Wire breakage / Reverse polarity protection	yes/ complete
Output function	3-wire, NO contact, PNP
Switching frequency	1 kHz
Approval acc. to	ATEX declaration of conformity 3116-4M
Device designation	Ⓢ II 3 G Ex nA II T4 X / II3 D Ex tD A22 IP67 T110°C
Design	rectangular, UNT
Dimensions	28 x 5 x 6 mm
Housing material	plastic, PP
Material active area	Plastic, PP
Tightening torque fixing screw	0.4 Nm
Connection	cable
Cable quality	3 mm, grey, Lif9Y-11Y, PUR, 2 m Suited for E-ChainSystems® acc. to manufacturers declaration H1063M
Cable cross section	3 x 0.14 mm ²
Vibration resistance	55 Hz (1 mm)
Shock resistance	30 g (11 ms)
Protection class	IP67
MTTF	2283 years acc. to SN 29500 (Ed. 99) 40 °C
Mounting on the following profiles	.
Cylindrical design	○ □ □ ○
Switching state	LED yellow
Included in scope of supply	cable clip

Wiring diagram

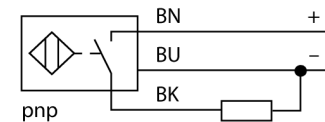

Functional principle

Magnetic field sensors are activated by magnetic fields. They are applied to detect the position of pneumatic cylinders. Magnetic fields can permeate non-magnetizable metals. A permanent magnet attached to the piston is thus detected through the aluminium wall of the cylinder.

Magnetic field sensor for pneumatic cylinders BIM-UNT-AP6X/3GD

TURCK

Industrial
Automation

Mounting instructions / Description

mounting instructions









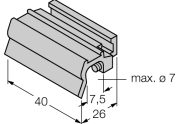

Insert the sensor in the groove from above. Mount the sensors as follows using the patented wing screw: The wing screw features a left-hand female thread. Two small plastic lips keep the screw in position, ready-to-install. Turn the screw clockwise. The screw moves out of the thread and hits the upper grooves with the wings. The sensor is thus pressed down and locked. Use a standard screw driver or a 2.5 mm Allen key to fasten the screw with a quarter turn. A fixing torque of 0.4 Nm is sufficient for safe mounting without damaging the cylinder. The sensor now withstands axial and radial tensile load of $F=100\text{N}$ applied on the cable. Cable clips are included in the scope of delivery. They enable smooth cable routing in the groove. Mounting accessories for other cylinder sizes have to be ordered separately.

**Magnetic field sensor
for pneumatic cylinders
BIM-UNT-AP6X/3GD**

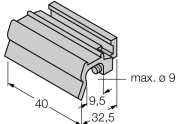
TURCK

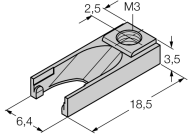
Industrial
Automation

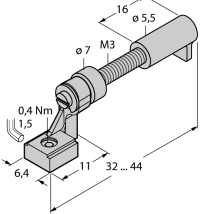
Accessories

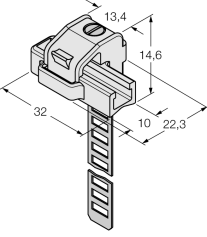
Type code	Ident no.	Description	Dimension drawing
KLZ1-INT	6970410	Accessories for mounting the BIM-UNT sensor on round cylinders; diameter: 32...40 mm; material: Aluminium; further mounting accessories for other cylinder diameters on request	
KLZ2-INT	6970411	Accessories for mounting the BIM-UNT sensor on  tie-rod cylinders; diameter: 50...63 mm; material: Aluminium; further mounting accessories for other cylinder diameters on request	
UNT-Stopper	4685751	Accessories for finetuning the switchpoint on  T-groove cylinders; snap-locked in the BIM-UNT fixture; suited for multiple use; material: plastic	
UNT-Justage	4685750	Accessories for finetuning the switchpoint on  T-groove cylinders; snap-locked in the BIM-UNT fixture; suited for multiple use; material: metal/plastic	
KLRC-UNT1	6970626	Accessories for mounting on  cylinders; diameter: 8...25 mm; material: PA 6I/6T / nickel silver; Fire-hazard classification acc. to UL94 - V2	

**Magnetic field sensor
for pneumatic cylinders
BIM-UNT-AP6X/3GD**

Accessories

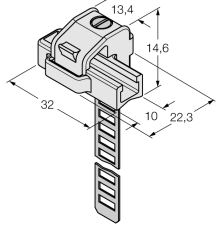
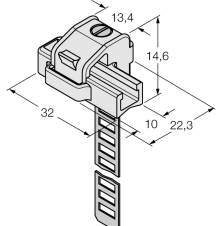
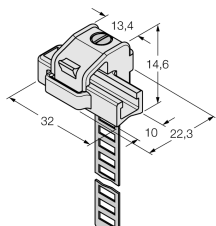
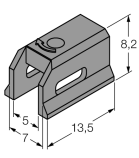
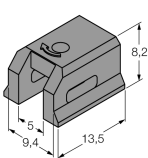
Type code	Ident no.	Description	Dimension drawing
KLRC-UNT2	6970627	Accessories for mounting on \bigcirc cylinders; diameter: 25...63 mm; material: PA 6I/6T / nickel silver; Fire-hazard classification acc. to UL94 - V2	
KLRC-UNT3	6970628	Accessories for mounting the BIM-UNT sensor on \bigcirc round cylinders; diameter: 63...130 mm; material: PA 6I/6T / nickel silver; Fire-hazard classification acc. to UL94 - V2	
KLRC-UNT4	6970629	Accessories for mounting the BIM-UNT sensor on \bigcirc round cylinders; diameter: 130...250 mm; material: PA 6I/6T / nickel silver; Fire-hazard classification acc. to UL94 - V2	
KLDT-UNT2	6913351	Accessories for mounting the BIM-UNT sensor on dovetail cylinders; groove width: 7 mm; material: PPS	
KLDT-UNT3	6913352	Accessories for mounting the BIM-UNT sensor on \square dovetail groove cylinders; groove width: 9.4 mm; material: PPS	

**Magnetic field sensor
for pneumatic cylinders
BIM-UNT-AP6X/3GD**

TURCK

Industrial
Automation

Accessories

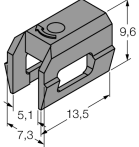
Type code	Ident no.	Description	Dimension drawing
KLDT-UNT6	6913355	Accessories for mounting on  dovetail groove cylinders; groove width: 7.35 mm; material: PPS	

Magnetic field sensor for pneumatic cylinders BIM-UNT-AP6X/3GD

TURCK

Industrial
Automation

Operating manual

Intended use

This device fulfills the directive 94/9/EC and is suited for use in explosion hazardous areas according to EN60079-0:2009, EN60079-15:2005 and EN61241-1:2004.

In order to ensure correct operation to the intended purpose it is required to observe the national regulations and directives.

For use in explosion hazardous areas conform to classification

II 3 G and II 3 D (Group II, Category 3 G, electrical equipment for gaseous atmospheres and category 3 D, electrical equipment for dust atmospheres).

Marking (see device or technical data sheet)

Ⓔ II 3 G und Ex nA II T4 X acc. to EN 60079-0:2009 and EN 60079-15:2005 and Ⓔ II 3 D Ex tD A22 IP67 T 110°C acc. to EN60079-0:2009 and EN 61241-1:2004

Local admissible ambient temperature

-25...+55 °C

Installation / Commissioning

These devices may only be installed, connected and operated by trained and qualified staff. Qualified staff must have knowledge of protection classes, directives and regulations concerning electrical equipment designed for use in explosion hazardous areas.

Please verify that the classification and the marking on the device comply with the actual application conditions.

Installation and mounting instructions

Avoid static charging of cables and plastic devices. Please only clean the device with a damp cloth. Do not install the device in a dust flow and avoid build-up of dust deposits on the device.

If the devices and the cable could be subject to mechanical damage, they must be protected accordingly. They must also be shielded against strong electro-magnetic fields.

The pin configuration and the electrical specifications can be taken from the device marking or the technical data sheet.

In order to avoid contamination of the device, please remove possible blanking plugs of the cable glands or connectors only shortly before inserting the cable or opening the cable socket.

Special conditions for safe operation

Devices with terminal chamber (cable glands) have a weaker strain relief. Sufficient strain relief must be ensured or the cable must be stationary-mounted.

For devices with M12 connectors please use the supplied safety clip SC-M12/3GD.

Do not disconnect the plug-in connection or cable when energised.

Please attach a warning label permanently in an appropriate fashion in close proximity to the plug-in connection with the following inscription:

Nicht unter Spannung trennen / Do not separate when energized.

The device must be protected against any kind of mechanical damage and degrading UV-radiation. This is achieved through mounting in a standard T groove of a pneumatic cylinder.

Load voltage and operating voltage of this equipment must be provided by power supplies featuring safe isolation (IEC 60 364/ UL 508), which ensures that the rated voltage (24 VDC +20% = 28.8 VDC) of the equipment is not exceeded by more than 40%.

service / maintenance

Repairs are not possible. The approval expires if the device is repaired or modified by a person other than the manufacturer. The most important data from the approval are listed.