

**Magnetic field sensor  
for pneumatic cylinders  
BIM-UNT-AY1X/S1139 7M**

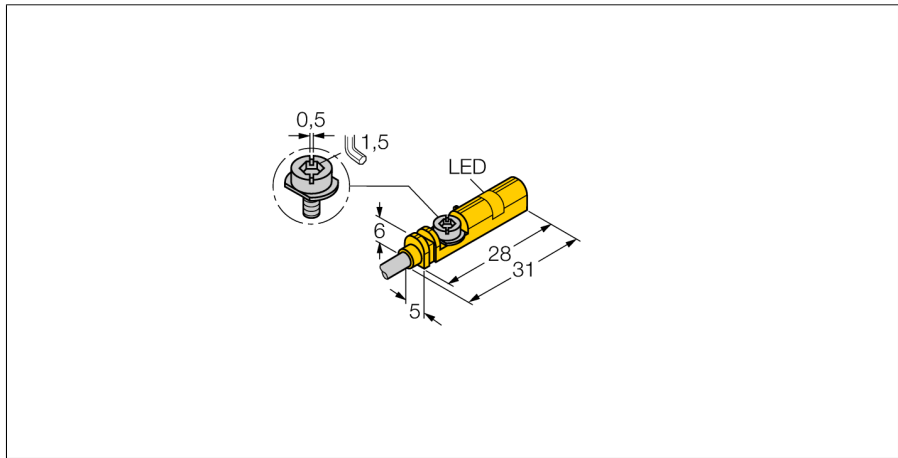

- ATEX category II 1 G, Ex Zone 0
- ATEX category II 1 D, Ex Zone 20
- For T-groove cylinders without mounting accessories
- Optional accessories for mounting on other cylindrical housings.
- One-hand mounting possible
- Fine adjustment tool and stopper directly mountable on the sensor
- Stable mounting
- Magneto-resistive sensor
- DC 2-wire, nom. 8.2 VDC
- Output acc. to DIN EN 60947-5-6 (NAMUR)
- Output with rectangular signal
- NO contact
- Cable connection

**Wiring diagram**

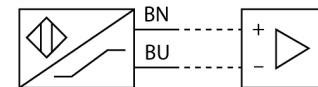

**Functional principle**

Magnetic field sensors are activated by magnetic fields. They are applied to detect the position of pneumatic cylinders. Magnetic fields can permeate non-magnetizable metals. A permanent magnet attached to the piston is thus detected through the aluminium wall of the cylinder.

<b>Type code</b>	BIM-UNT-AY1X/S1139 7M
Ident no.	4685764
<b>Pass speed</b>	≤ 10 m/s
Repeatability	≥ ± 0.1 mm
Temperature drift	≤ 0.1 mm
Hysteresis	≤ 1 mm
Ambient temperature	-25...+70 °C
<b>Output function</b>	2-wire, NAMUR
Switching frequency	1 kHz
Voltage	Nom. 8.2 VDC
Non-actuated current consumption	≤ 1.2 mA
Actuated current consumption	≥ 2.1 mA
<b>Approval acc. to</b>	KEMA 04 ATEX 1152 X
Internal capacitance (C) / inductance (L)	180 nF / 350 µH
Device designation	Ⓢ II 1 G Ex ia IIC T6 Ga/II 1 D Ex ia IIIC T95 °C (max. U <sub>i</sub> = 20 V, I <sub>i</sub> = 60 mA, P <sub>i</sub> = 80 mW)
<b>Design</b>	rectangular, UNT
Dimensions	28 x 5 x 6 mm
Housing material	plastic, PP
Material active area	Plastic, PP
Tightening torque fixing screw	0.4 Nm
Connection	cable
Cable quality	3 mm, blue, Lif9YYW, PVC, 7 m
Cable cross section	2 x 0.14 mm <sup>2</sup>
Vibration resistance	55 Hz (1 mm)
Shock resistance	30 g (11 ms)
Protection class	IP67
MTTF	2283 years acc. to SN 29500 (Ed. 99) 40 °C
Mounting on the following profiles	.
Cylindrical design	○ □ □ ○
<b>Switching state</b>	LED yellow
Included in scope of supply	cable clip

# Magnetic field sensor for pneumatic cylinders BIM-UNT-AY1X/S1139 7M

**TURCK**

Industrial  
Automation

Mounting instructions / Description

mounting instructions









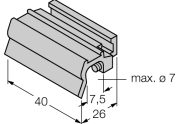

Insert the sensor in the groove from above. Mount the sensors as follows using the patented wing screw: The wing screw features a left-hand female thread. Two small plastic lips keep the screw in position, ready-to-install. Turn the screw clockwise. The screw moves out of the thread and hits the upper grooves with the wings. The sensor is thus pressed down and locked. Use a standard screw driver or a 2.5 mm Allen key to fasten the screw with a quarter turn. A fixing torque of 0.4 Nm is sufficient for safe mounting without damaging the cylinder. The sensor now withstands axial and radial tensile load of  $F=100\text{N}$  applied on the cable. Cable clips are included in the scope of delivery. They enable smooth cable routing in the groove. Mounting accessories for other cylinder sizes have to be ordered separately.

**Magnetic field sensor  
for pneumatic cylinders  
BIM-UNT-AY1X/S1139 7M**

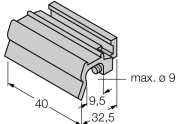
**TURCK**

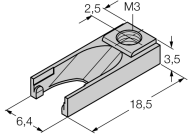
Industrial  
Automation

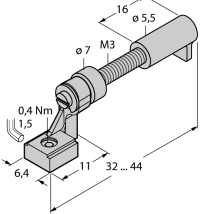
**Accessories**

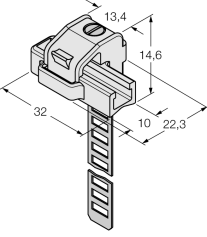

Type code	Ident no.	Description	Dimension drawing
KLZ1-INT	6970410	Accessories for mounting the BIM-UNT sensor on round cylinders; diameter: 32...40 mm; material: Aluminium; further mounting accessories for other cylinder diameters on request	 A perspective view of a U-shaped aluminium mounting bracket. The length is 40 mm. The height of the flange is 7.5 mm. The distance from the end of the flange to the start of the mounting groove is 26 mm. The maximum diameter of the groove is labeled as max. ø 7.
KLZ2-INT	6970411	Accessories for mounting the BIM-UNT sensor on  tie-rod cylinders; diameter: 50...63 mm; material: Aluminium; further mounting accessories for other cylinder diameters on request	 A perspective view of a U-shaped aluminium mounting bracket. The length is 40 mm. The height of the flange is 9.5 mm. The distance from the end of the flange to the start of the mounting groove is 32.5 mm. The maximum diameter of the groove is labeled as max. ø 9.
UNT-Stopper	4685751	Accessories for finetuning the switchpoint on  T-groove cylinders; snap-locked in the BIM-UNT fixture; suited for multiple use; material: plastic	 A perspective view of a plastic stopper. It has a T-shaped profile. The width of the base is 6.4 mm. The height of the base is 3.5 mm. The length of the base is 18.5 mm. The height of the T-shaped part is 2.5 mm. It has an M3 threaded hole.
UNT-Justage	4685750	Accessories for finetuning the switchpoint on  T-groove cylinders; snap-locked in the BIM-UNT fixture; suited for multiple use; material: metal/plastic	 A perspective view of a metal/plastic adjustment screw. The base has a width of 6.4 mm and a height of 1.5 mm. The length of the base is 11 mm. The total length of the screw is 32...44 mm. The diameter of the screw is ø 7. The thread is M3. The length of the threaded part is 16 mm. The diameter of the threaded part is ø 5.5. A torque specification of 0.4 Nm is indicated.
KLRC-UNT1	6970626	Accessories for mounting on  cylinders; diameter: 8...25 mm; material: PA 6I/6T / nickel silver; Fire-hazard classification acc. to UL94 - V2	 A perspective view of a mounting bracket. The width of the base is 32 mm. The height of the base is 13.4 mm. The distance from the end of the base to the start of the mounting groove is 10 mm. The height of the mounting groove is 14.6 mm. The distance from the end of the base to the end of the mounting groove is 22.3 mm.

**Magnetic field sensor  
for pneumatic cylinders  
BIM-UNT-AY1X/S1139 7M**

**TURCK**

Industrial  
Automation

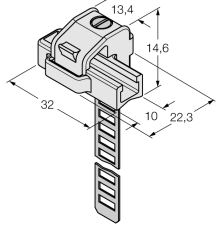
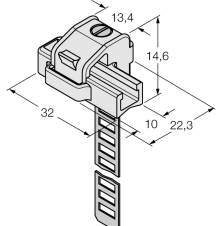
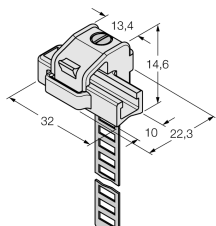
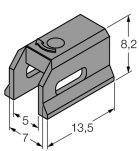
**Accessories**

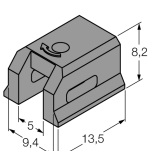
Type code	Ident no.	Description	Dimension drawing
KLRC-UNT2	6970627	Accessories for mounting on $\bigcirc$ cylinders; diameter: 25...63 mm; material: PA 6I/6T / nickel silver; Fire-hazard classification acc. to UL94 - V2	
KLRC-UNT3	6970628	Accessories for mounting the BIM-UNT sensor on $\bigcirc$ round cylinders; diameter: 63...130 mm; material: PA 6I/6T / nickel silver; Fire-hazard classification acc. to UL94 - V2	
KLRC-UNT4	6970629	Accessories for mounting the BIM-UNT sensor on $\bigcirc$ round cylinders; diameter: 130...250 mm; material: PA 6I/6T / nickel silver; Fire-hazard classification acc. to UL94 - V2	
KLDT-UNT2	6913351	Accessories for mounting the BIM-UNT sensor on dovetail cylinders; groove width: 7 mm; material: PPS	
KLDT-UNT3	6913352	Accessories for mounting the BIM-UNT sensor on  dovetail groove cylinders; groove width: 9.4 mm; material: PPS	

**Magnetic field sensor  
for pneumatic cylinders  
BIM-UNT-AY1X/S1139 7M**

**TURCK**

Industrial  
Automation

**Accessories**

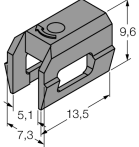
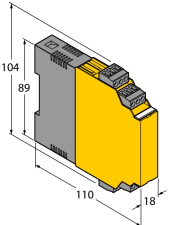
Type code	Ident no.	Description	Dimension drawing
KLDT-UNT6	6913355	Accessories for mounting on  dovetail groove cylinders; groove width: 7.35 mm; material: PPS	
IM1-22EX-R	7541231	Isolating switching amplifier, dual-channel; 2 relay outputs NO; input NAMUR signal; selectable ON/OFF mode for wire-break and short-circuit monitoring; adjustable signal flow (NO/ NC mode); removable terminal blocks; 18 mm width; universal voltage supply unit	

# Magnetic field sensor for pneumatic cylinders BIM-UNT-AY1X/S1139 7M

**TURCK**

Industrial  
Automation

## Operating manual

### Intended use

This device fulfills the directive 94/9/EC and is suited for use in explosion hazardous areas according to EN60079-0:2009, -11:2012, -26:2007. In order to ensure correct operation to the intended purpose it is required to observe the national regulations and directives.

### For use in explosion hazardous areas conform to classification

II 1 G and II 1 D (Group II, Category 1 G, electrical equipment for gaseous atmospheres and category 1 D, electrical equipment for dust atmospheres).

### Marking (see device or technical data sheet)

Ex II 1 G and Ex ia IIC T6 and Ex II 1 D Ex ia IIIC T95°C acc. to EN60079-0, -11 and -26

### Local admissible ambient temperature

ATEX category II 2 G electrical equipment -40...+70°C, category II 1 D -25...+70 °C. The corresponding temperature classes are provided in the ATEX type-examination certificate.

### Installation / Commissioning

These devices may only be installed, connected and operated by trained and qualified staff. Qualified staff must have knowledge of protection classes, directives and regulations concerning electrical equipment designed for use in explosion hazardous areas. Please verify that the classification and the marking on the device comply with the actual application conditions.

This device is only suited for connection to approved Exi circuits compliant to EN60079-0 and -11. Please observe the maximum admissible electrical values.

After connection to other circuits the sensor may no longer be used in Exi installations. When interconnected to (associated) electrical equipment, it is required to perform the "Proof of intrinsic safety" (EN60079-14).

### Installation and mounting instructions

Avoid static charging of cables and plastic devices. Please only clean the device with a damp cloth. Do not install the device in a dust flow and avoid build-up of dust deposits on the device.

If the devices and the cable could be subject to mechanical damage, they must be protected accordingly. They must also be shielded against strong electro-magnetic fields.

The pin configuration and the electrical specifications can be taken from the device marking or the technical data sheet.

In order to avoid contamination of the device, please remove possible blanking plugs of the cable glands or connectors only shortly before inserting the cable or opening the cable socket.

### Special conditions for safe operation

The device must be protected against any kind of mechanical damage.

### service / maintenance

Repairs are not possible. The approval expires if the device is repaired or modified by a person other than the manufacturer. The most important data from the approval are listed.