

**Magnetic field sensor  
for detection of ferromagnetic parts  
NIMFE-M12/4,6L88-UP6X-H1141**

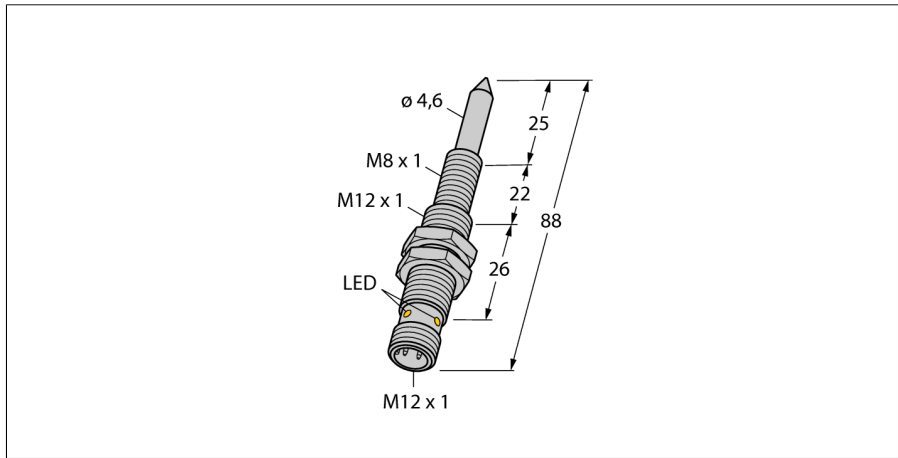

- Threaded barrel, M12/M8
- Chrome-plated brass
- 3-wire DC, 10...30 VDC
- NC/NO parametrizable with teach adapter VB2-SP1
- Male M12 x 1

**Wiring diagram**

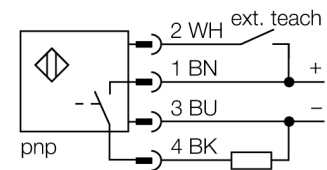

**Functional principle**

The magnetic field sensors for welding nuts are available in two different versions, with different signal intensities and diameters. Ferromagnetic spares which differ strongly in their material properties and diameters can be detected. A target part has to be located within the so called sensitive area in order to be detected. The internal sensor signal reaches the maximum intensity if the sensitive area is completely covered by the target. Partial coverage is also possible.

Sensitive area  $S = 9\text{mm}$

Within this area the sensor signal changes when components are connected.

Maximum range  $M = 13\text{mm}$

In case of complete coverage of the sensitive area the maximum signal intensity is achieved.

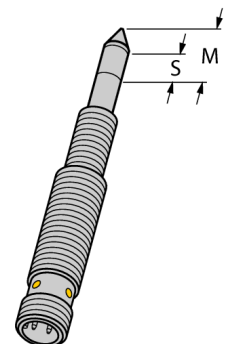

<b>Type code</b>	NIMFE-M12/4,6L88-UP6X-H1141
Ident no.	1600608
<b>Ambient temperature</b>	-25...+70 °C
<b>Operating voltage</b>	10...30VDC
Residual ripple	≤ 10 % $U_{s}$
DC rated operational current	≤ 200 mA
No-load current $I_0$	≤ 15 mA
Residual current	≤ 0.1 mA
Rated insulation voltage	≤ 0.5 kV
Short-circuit protection	yes/ cyclic
Voltage drop at $I_s$	≤ 1 V
Wire breakage / Reverse polarity protection	yes/ complete
Output function	3-wire, connection programmable, PNP
<b>Design</b>	threaded barrel, M12/4,6L88
Dimensions	88 mm
Housing material	metal, CuZn, chrome-plated
Material active area	Metal, CuZn, chrome-plated
Max. tightening torque housing nut	10 Nm
Connection	male, M12 x 1
Vibration resistance	55 Hz (1 mm)
Shock resistance	30 g (11 ms)
Protection class	IP67
MTTF	874 years acc. to SN 29500 (Ed. 99) 40 °C
<b>Power-on indication</b>	LED green
Switching state	LED yellow

**Magnetic field sensor  
for detection of ferromagnetic parts  
NIMFE-M12/4,6L88-UP6X-H1141**

examples of use

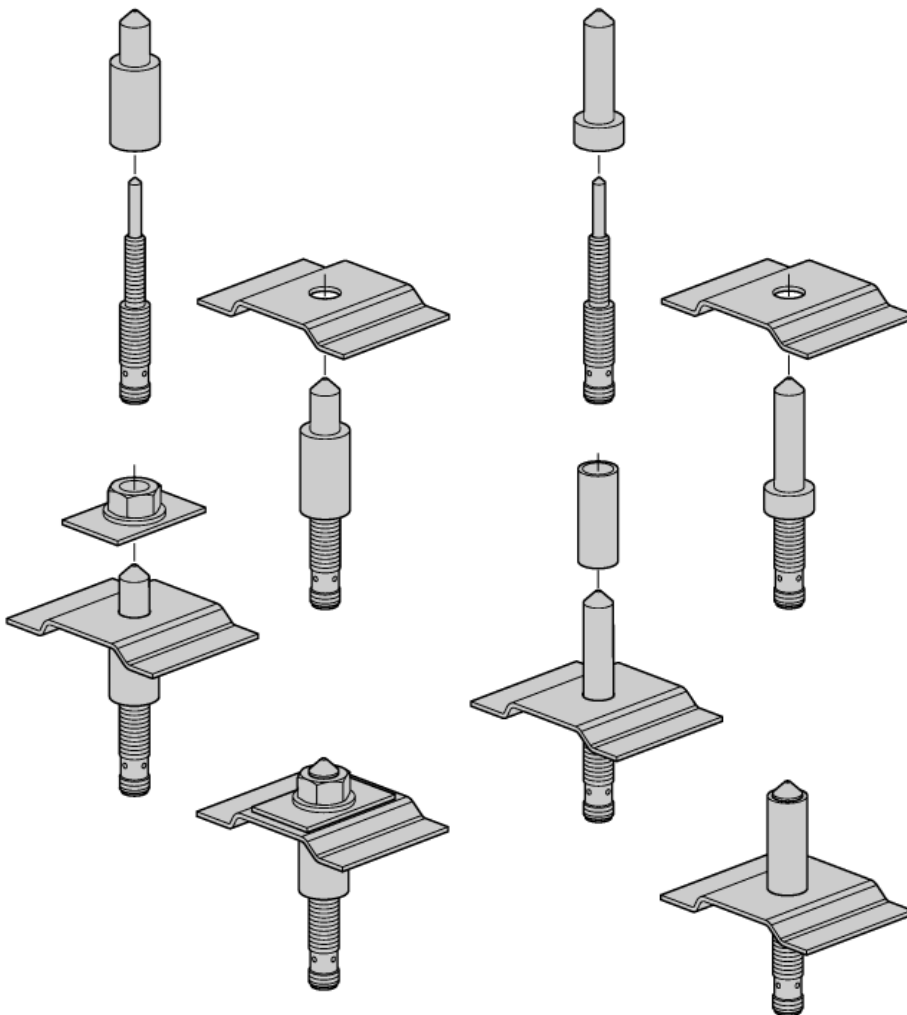

The magnetic field sensor is especially suited for the detection of welding nuts as well as spacer or reinforcing sleeves. The parts have to be made of ferromagnetic material in order to guarantee correct performance. Most applications need center bolts to retain the welding nuts and reinforcing sleeves and thus provide mechanical protection of the sensors. These bolts have to be made of non-ferromagnetic material, like stainless steel for example. Center bolts are not available at Turck, as these have to be produced individually and adjusted to the correspondent application. The weld sensor detects targets with diameters between 10 and 12mm easily.

**Magnetic field sensor  
for detection of ferromagnetic parts  
NIMFE-M12/4,6L88-UP6X-H1141**

Parameterisation with the teach adapter:

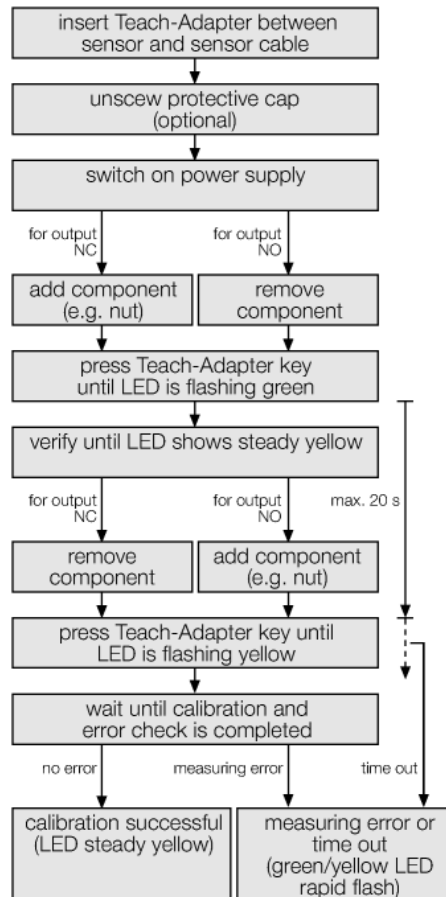
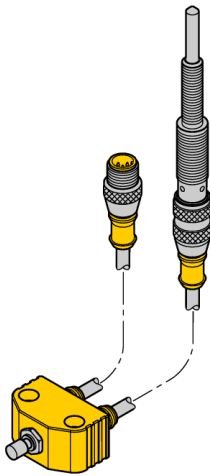

The measuring signal in the sensor is influenced by the diameter and the material characteristics of the center bolt, but also by the cover of the sensitive area. Therefore each sensor has to be conditioned to the operating environment, i.e. to the applied sleeves or protective caps and the target (nut, sleeve etc.) In order to calibrate a sensor, the teach adapter VB2-SP1 made by Turck is needed.

**Error display**

If the output is in switch-on state and the error messages 'overload' i.e. 'short circuit' are signaled, the output is immediately switched off. Within one second the sensor checks if the state of short circuit still remains, if not, the output is switched-on again. The states of 'overload' or 'short circuit' are signaled yellow by the LED with 1 Hz. Each sensor monitors the internal signals and hardware components. The output is switched-off by the following errors:

- Interruption of the sensor signal (e.g. by a magnetic field)
- Excess temperature (internal device temperature >100°C)
- Defective hardware

Sensor errors are indicated by alternate flashing green and yellow LEDs. The sensor errors are usually self-resetting, i.e. the sensor changes automatically to the normal operating state, after the error was corrected. After switching on the operating voltage the sensor checks its operating parameters. If errors occur during the checking process, the sensor remains in the error state (green LED blinking). The output cannot be switched-on in this state. A new calibration with the teach adapter is required.

**Magnetic field sensor  
for detection of ferromagnetic parts  
NIMFE-M12/4,6L88-UP6X-H1141**

**Accessories**

Type code	Ident no.	Description	Dimension drawing
BSS-12	6901321	Mounting bracket for smooth and threaded barrel devices; material: Polypropylene	
VB2-SP1	6999084	Teach adapter	