

**Ultrasonic sensor
diffuse mode sensor
T30UXUB**

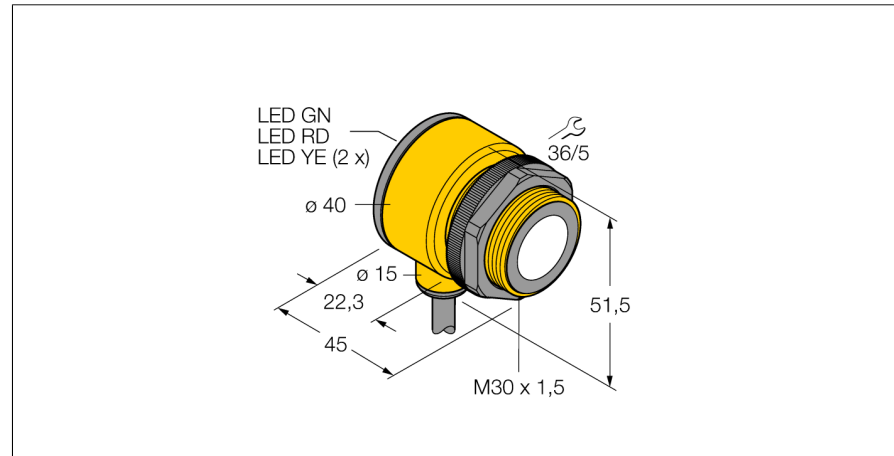

- Compact design
- Cable, 4-pin, 2 m
- Analog output 0...10 V
- Response time adjustable
- Integrated temperature compensation
- Measuring range adjustable via teach-in

Wiring diagram

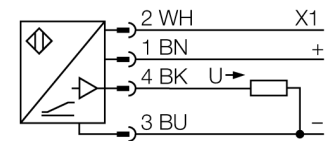

Functional principle

Ultrasonic sensors detect a multitude of objects contactless and wear-free with ultrasonic waves. Regardless of whether the object is transparent or opaque, metallic or non-metallic, liquid, solid or powdery. Even environmental conditions such as spray, dust or rain hardly affect their function.

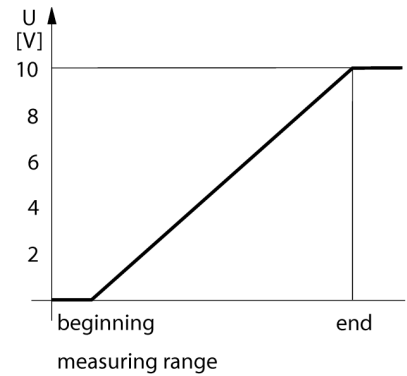

Type code	T30UXUB
Ident no.	3080468
Design	cylindrical/threaded, T30U
Dimensions	Ø40 x 45 mm
Housing material	plastic, Polyester
Connection	cable, 2
Protection class	IP67
Ambient temperature	-40...+70 °C
Power-on indication	LED
Operating voltage	10...30VDC
Response time	92 ms
Voltage output	0...10V
Hysteresis	≤ 3 mm
Short-circuit protection	yes/ cyclic
Reverse polarity protection	complete
Wire breakage protection	yes
Operating mode	diffuse mode ultrasonic sensor
Range	20...200 cm
Ultrasound frequency	174 kHz
Repeatability	≥ ± 1 mm
Edge lengths of the nominal actuator	100 mm

**Ultrasonic sensor
diffuse mode sensor
T30UXUB**

Accessories

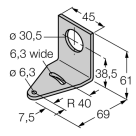
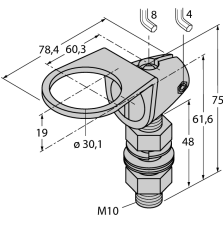
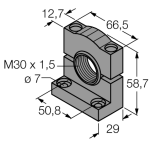
Type code	Ident no.	Description	Dimension drawing
SMB30A	3032723	Mounting bracket, stainless steel, for sensors with 30 mm thread	 <p>Technical drawing of the SMB30A mounting bracket. Dimensions include: top width 45, hole diameter $\varnothing 30,5$, hole offset 6,3 wide, hole diameter $\varnothing 6,3$, hole depth 38,5, hole offset 6,1, bottom width 7,5, and a radius of R 40.</p>
SMB30FAM10	3011185	Mounting bracket, stainless steel, for M10 x 1.5 thread, thread length 30 mm	 <p>Technical drawing of the SMB30FAM10 mounting bracket. Dimensions include: top width 78,4, hole diameter $\varnothing 60,3$, hole offset 19, hole diameter $\varnothing 30,1$, hole depth 48, total height 75, and a threaded section of M10 with a length of 61,6.</p>
SMB30SC	3052521	Mounting bracket, PBT black; for 30 mm thread; with 4 screws M5 x 0.8	 <p>Technical drawing of the SMB30SC mounting bracket. Dimensions include: top width 12,7, hole diameter $\varnothing 66,5$, hole offset 58,7, hole diameter $\varnothing 7$, hole depth 50,8, and a width of 29.</p>