

**Photoelectric sensor
diffuse mode sensor
For color analysis
QC50A3P6XDWQ**

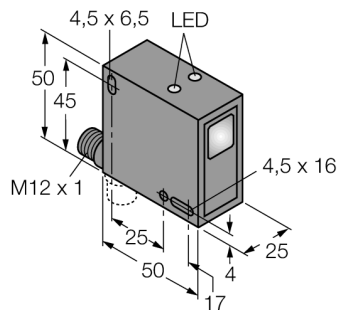

- Male M12 x 1, 8-pin
- Connector rotatable by 90 °
- Protection class IP67
- LCD display
- Non-volatile EEPROM memory
- Response time: 335 µs
- Operating voltage: 10...30 VDC
- 3 PNP switching outputs
- Individually programmable

Wiring diagram

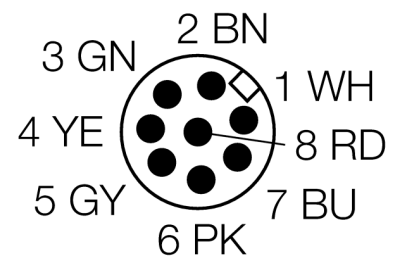
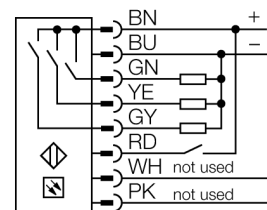

Functional principle

The QC50 is a user-friendly compact colour sensor for detection of one, two or three colours, using modulated white light and electronic red, green and blue filters (R, G, B). Due to its compact size it can be easily mounted almost everywhere. The configuration options comprise a programming mode to set the colour detection parameters, as well as the setup mode for adjustment of a selectable output switch-off delay. The sensor is equipped with three transistor outputs which can be adjusted individually for colour detection or for colour plus colour intensity distinction. The sensor is equipped with two buttons (set and select) as well as with a 4-digit LCD display, an output LED and three output status LEDs (one per output).

Type code	QC50A3P6XDWQ
Ident no.	3070826
Operating mode	colour sensor
Light type	white
Light spot diameter	4 mm
Range	0...20 mm
Ambient temperature	-10...+55 °C
Operating voltage	10...30VDC
No-load current I ₀	≤ 40 mA
Short-circuit protection	yes
Reverse polarity protection	yes
Output function	3 x NO, PNP
Switching frequency	2 kHz
Readiness delay	≤ 500 ms
Response time	< 0.335 ms
Design	rectangular, QC50
Dimensions	50 x 25 x 50 mm
Housing material	plastic, ABS, black
Lens	glass
Connection	male, M12 x 1
Protection class	IP67
Switching state	LED yellow

**Photoelectric sensor
diffuse mode sensor
For color analysis
QC50A3P6XDWQ**

TURCK

Industrial
Automation

Accessories

Type code	Ident no.	Description	Dimension drawing
SMBQC50	3071679	Montagewinkel, Metall, für Sensoren der Baureihe QC50 und QCX50	