

**Photoelectric sensor  
convergent mode sensor  
miniature sensor  
VS1AP5CV10**

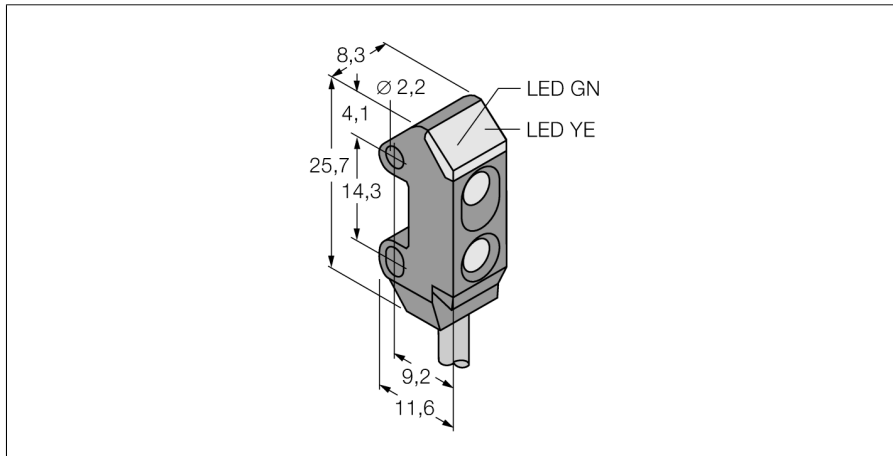

- Cable 2 m
- Very high excess gain
- Operating voltage: 10...30 VDC
- PNP switching output, light operation

**Wiring diagram**

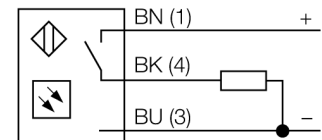

**Functional principle**

Convergent mode sensors are equipped with a lens in front of the emitter diode that produces a small and intense focal point at a defined distance from the sensor. Similar to diffuse mode sensors, the light reflected by the target is evaluated. Convergent mode sensors are ideal for detection of small targets or colour marks and edge guiding or positioning control of transparent materials. The targets must always be within the focal depth of the sensors. The focal depth is defined as the area in front of or behind the focal point within which the object can be detected. Based on the intense light concentration in the focal point, convergent mode sensors are capable of detecting targets with a low reflectivity.

**Excess gain curve**

Excess gain in relation to the distance

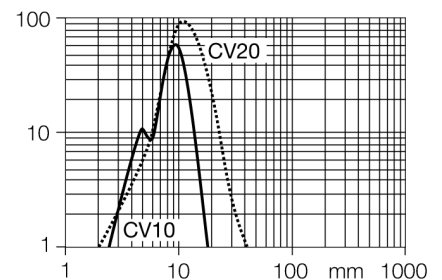

<b>Type code</b>	VS1AP5CV10
Ident no.	3056494
<b>Operating mode</b>	convergent mode sensor
Light type	red
Wavelength	630 nm
Focal distance	10 mm
Ambient temperature	-20...+55 °C
<b>Operating voltage</b>	10...30VDC
Residual ripple	< 10 % U <sub>s</sub>
DC rated operational current	≤ 50 mA
No-load current I <sub>0</sub>	≤ 25 mA
Short-circuit protection	yes
Reverse polarity protection	yes
Output function	NO, light operation, PNP
Current output	0...50mA
Switching frequency	≤ 500 Hz
Readiness delay	≤ 100 ms
<b>Design</b>	rectangular, VS1
Dimensions	11.6 x 8.3 x 25.7 mm
Housing material	plastic, ABS, black
Lens	plastic, acrylic
Connection	cable, PVC
Cable length	2 m
Cable cross section	3 x 0.34 mm <sup>2</sup>
Protection class	IP54
<b>Power-on indication</b>	LED green
Switching state	LED yellow
Error indication	LED green flashing

**Photoelectric sensor  
convergent mode sensor  
miniature sensor  
VS1AP5CV10**

**TURCK**

Industrial  
Automation

**Accessories**

Type code	Ident no.	Description	Dimension drawing
SMBVS1T	3055496	Mounting bracket, stainless steel, rectangular, for VS1	
SMBVS1TC	3056795	Mounting bracket, stainless steel, rectangular, for VS1	
SMBVS1S	3055554	Mounting bracket, stainless steel, rectangular, for VS1	
SMBVS1SC	3056797	Mounting bracket, stainless steel, rectangular, for VS1	