

**Photoelectric sensor
convergent mode sensor
QS18VP6CV15Q**

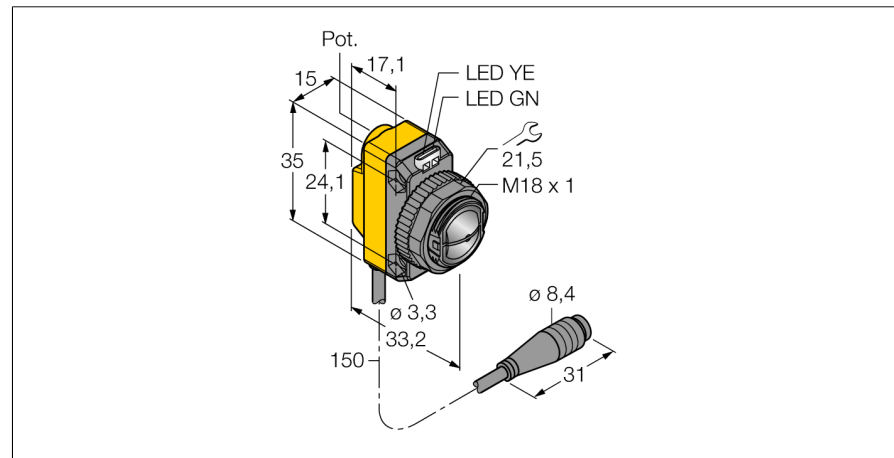

- Cable with male end, 4-pin, PVC, 150 mm, 8 mm
- Protection class IP67
- LED all-round visible
- Sensitivity adjusted via potentiometer

Wiring diagram



Type code	QS18VP6CV15Q
Ident no.	3061643
Operating mode	convergent mode sensor
Light type	red
Wavelength	660 nm
Focal distance	16 mm
Ambient temperature	-20...+70 °C
Operating voltage	10...30VDC
Residual ripple	< 10 % U _s
DC rated operational current	≤ 100 mA
Short-circuit protection	yes
Reverse polarity protection	yes
Output function	NO/NC , PNP
Switching frequency	≤ 800 Hz
Readiness delay	≤ 100 ms
Design	rectangular, QS18
Dimensions	33.2 x 15 x 35 mm
Housing material	plastic, ABS
Lens	plastic, acrylic
Connection	cable with connector, PVC, Ø 8 mm
Cable length	0.15 m
Protection class	IP67
Power-on indication	LED green
Switching state	LED yellow
Error indication	LED green flashing
Excess gain indication	LED yellow flashing

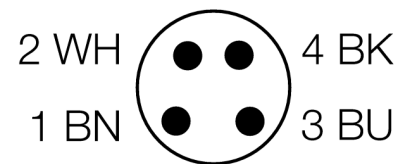

Functional principle

Convergent mode sensors are equipped with a lens in front of the emitter diode that produces a small and intense focal point at a defined distance from the sensor. Similar to diffuse mode sensors, the light reflected by the target is evaluated. Convergent mode sensors are ideal for detection of small targets or colour marks and edge guiding or positioning control of transparent materials. The targets must always be within the focal depth of the sensors. The focal depth is defined as the area in front of or behind the focal point within which the object can be detected. Based on the intense light concentration in the focal point, convergent mode sensors are capable of detecting targets with a low reflectivity.

Excess gain curve

Excess gain in relation to the distance

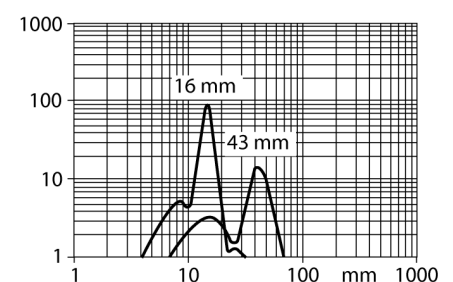

Photoelectric sensor
convergent mode sensor
QS18VP6CV15Q

TURCK

Industrial
Automation

Accessories

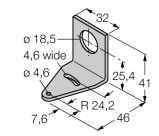
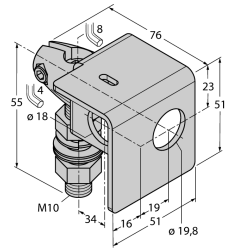
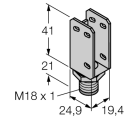
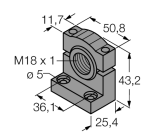
Type code	Ident no.	Description	Dimension drawing
SMB18A	3033200	Mounting bracket, stainless steel, for sensors with 18 mm thread	
SMB18AFAM10	3012558	Mounting bracket, material VA 1.4401, for M10 x 1.5 thread, thread length 18 mm	
SMBQS18A	3069721	Mounting bracket, stainless steel, for 18 mm thread	
SMB18SF	3052519	Mounting bracket, PTB black steel, for sensors with 18 mm thread	

Wiring accessories

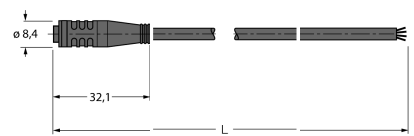
Type code	Ident no.	Description	Dimension drawing
PKG4S-2/TEL	6627370	Connection cable, female Ø 8 mm, straight, 4-pin, snap-on type, cable length: 2 m; sheath material: PVC, sheath color: black, cULus approved, RoHS conform, protection class IP67	

Photoelectric sensor
convergent mode sensor
QS18VP6CV15Q

Wiring accessories

Type code	Ident no.	Description	Dimension drawing
PKW4S-2/TEL	6627373	Connection cable, female Ø 8 mm, straight, 4-pin, snap-on type, cable length: 2 m; sheath material: PVC, sheath color: black, cULus approved, RoHS conform, protection class IP67	