

**Photoelectric sensor
convergent mode sensor
miniature sensor
VS2AP5CV15Q**

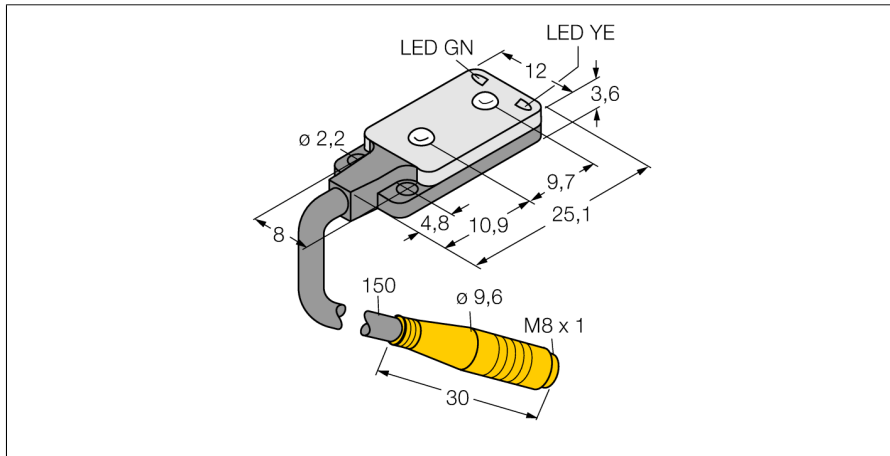

- Cable with male end M8 x 1, 3-pin, 150 mm
- Operating voltage: 10...30 VDC
- Ultraflat design
- PNP switching output, light operation

Wiring diagram

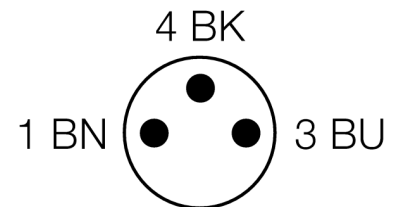
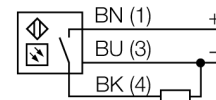

Type code	VS2AP5CV15Q
Ident no.	3063075
Operating mode	convergent mode sensor
Light type	red
Wavelength	660 nm
Focal distance	15 mm
Ambient temperature	-20...+55 °C
Operating voltage	10...30VDC
Residual ripple	< 10 % U _s
DC rated operational current	≤ 50 mA
No-load current I ₀	≤ 25 mA
Short-circuit protection	yes
Reverse polarity protection	yes
Output function	NO, light operation, PNP
Switching frequency	≤ 500 Hz
Readiness delay	≤ 150 ms
Design	rectangular, VS2
Dimensions	4.7 x 12 x 25.1 mm
Housing material	plastic, ABS
Lens	plastic, acrylic
Connection	cable with connector, PVC, M8 x 1
Protection class	IP67
Power-on indication	LED green
Switching state	LED yellow
Error indication	LED green flashing
Alarm display	LED yellow flashing

Functional principle

Convergent mode sensors are equipped with a lens in front of the emitter diode that produces a small and intense focal point at a defined distance from the sensor. Similar to diffuse mode sensors, the light reflected by the target is evaluated. Convergent mode sensors are ideal for detection of small targets or colour marks and edge guiding or positioning control of transparent materials. The targets must always be within the focal depth of the sensors. The focal depth is defined as the area in front of or behind the focal point within which the object can be detected. Based on the intense light concentration in the focal point, convergent mode sensors are capable of detecting targets with a low reflectivity.

Excess gain curve

Excess gain in relation to the distance

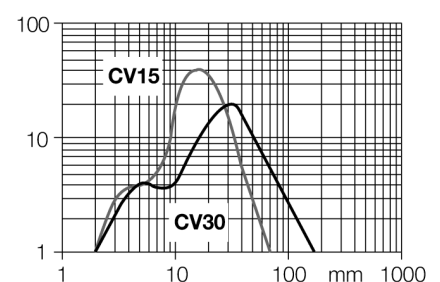

**Photoelectric sensor
convergent mode sensor
miniature sensor
VS2AP5CV15Q**

Accessories

Type code	Ident no.	Description	Dimension drawing
SMBVS2RA	3058603	mounting bracket, straight	

Wiring accessories

Type code	Ident no.	Description	Dimension drawing
PKG3M-2/TEL	6625058	Connection cable, female M8, straight, 3-pin, cable length: 2 m, sheath material: PVC, black; cULus approval; other cable lengths and qualities available, see www.turck.com	
PKW3M-2/TEL	6625064	Connection cable, female M8, angled, 3-pin, cable length: 2 m, sheath material: PVC, black; cULus approval; other cable lengths and qualities available, see www.turck.com	