

**Photoelectric sensor
diffuse mode sensor
laser measuring system
LH150IX485QP**

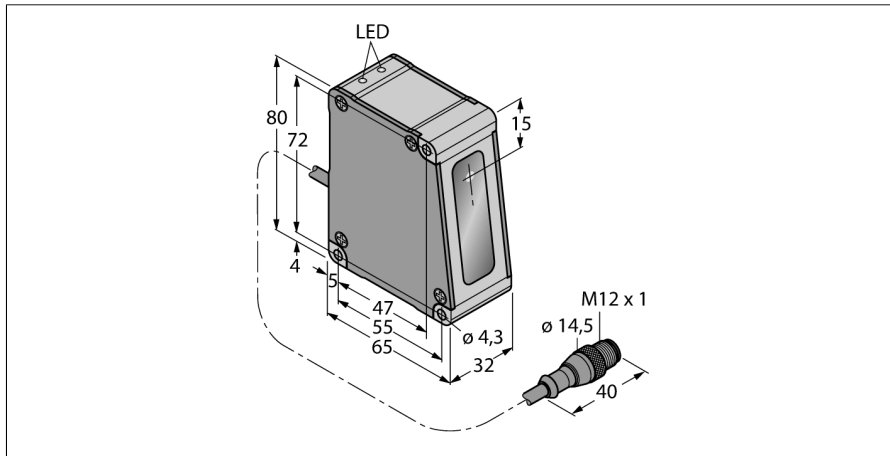

- Indication of signal intensity
- Measuring range 100...200 mm
- Max. resolution 10 µm
- Laser beam at 150 mm distance: 225 µm
- Thickness measurement, nominal 50 mm via connection of a second LH150 (adapter CSB3-M1281M1282-LH required)
- Operating voltage 18...30 VDC
- Analog output 4...20 mA
- RS485 serial communication
- Adjustable via enclosed software
- USB converter INTUSB458-LH required
- 8-pin Y-piece CSB-M1280M1280-LH required

Type code	LH150IX485QP
Ident no.	3011952
Operating mode	Diffuse mode laser sensor (triangulation)
Light type	red
Wavelength	670 nm
Laser class	▲ 2
Range	100...200 mm
Ambient temperature	-10...+45 °C
Operating voltage	18...30VDC
Residual ripple	< 10 % U _n
DC rated operational current	≤ 250 mA
Short-circuit protection	yes/ cyclic
Reverse polarity protection	yes
Output function	4 ... 20 mA, analog output
Current output	4...20mA
Load resistance	≤ 1000 Ω
Readiness delay	≤ 1.25 s
Design	rectangular, LH
Dimensions	65 x 32 x 80 mm
Housing material	metal, AL, black
Lens	glass
Connection	cable with connector, PVC, M12 x 1
Cable length	0.15 m
Cable cross section	8 x 0.34 mm ²
Protection class	IP67
Power-on indication	LED green

Wiring diagram

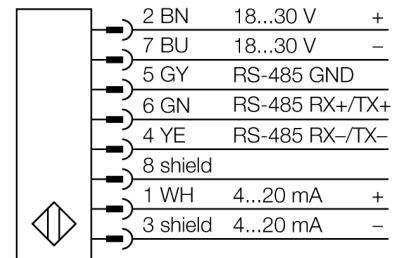

Functional principle

The functional principle of the LH sensors is based on optical laser triangulation. The emitter and the optics create a light source that is directed towards a target. The target reflects the laser beam back to the receiver lens of the sensor, from where it then falls onto the CMOS receiving element. The target's distance to the receiver determines the angle at which the light hits the receiver element. The integrated microprocessor uses this angle to analyse the target's position and to create a corresponding output signal.

Photoelectric sensor
diffuse mode sensor
laser measuring system
LH150IX485QP

TURCK

Industrial
Automation

Accessories

Type code	Ident no.	Description	Dimension drawing
SMBLH150	3012721	Mounting bracket, anodized aluminium, black, for LH150 sensor pair, distance and thickness measurement	
SMBLH1	3012717	Mounting bracket, anodized aluminium, black, for LH sensor, laterally mounted on wall	

Wiring accessories

Type code	Ident no.	Description	Dimension drawing
INTUSB485-LH	3013262	RS485-USB converter cable, male M12 x 1, 8-pin on USB male type B, for programming of one or more LH-Sensors via PC	
CSB-M1280M1280-LH	3013239	Y-piece, male M12 x 1 on 2 x female M12 x 1, 8-pin, -40...+80 ° C, IP67, for connection of LH sensor to power and INTUSB485-LH	
CSB3-M1281M1282-LH	3014418	Y-piece, male M12 x 1 with 0.30 m cable on 3 x female M12 x 1 with 0.60 m cable, 8-pin, -40...+150 ° C, IP67, for connection of 2 LH sensors to power and INTUSB485-LH	
MQLH-806-F	3011680	Connection cable, PVC, shielded, length 2 m, female M12 x 1, 8-pin, open end	
MQLH-801-MM	3012407	Extension cable, PVC, shielded, 0.3 m, male M12 x 1, 8-pin on male M12 x 1, 8-pin	
MQLH-806-MF	3012398	Extension cable, PVC, shielded, 2 m, female M12 x 1, 8-pin on male M12 x 1, 8-pin	

