

**Photoelectric sensor
laser measuring system
LG5A65PI**

TURCK

Industrial
Automation

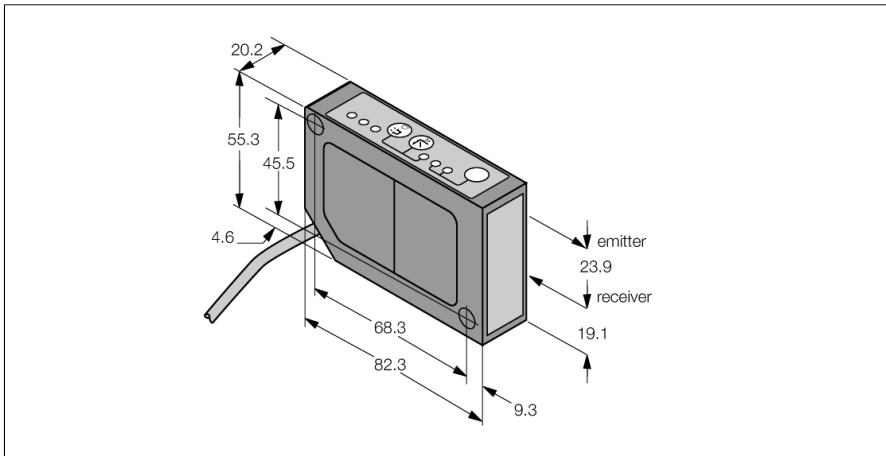

- Connection cable, 2 m
- Measuring range 45...60 mm
- Focal point at 70 mm
- Operating voltage 12...30 VDC
- Analog output 4...20 mA
- Indication of signal intensity
- Alarm output
- slow, medium and fast operation mode adjustable

Wiring diagram

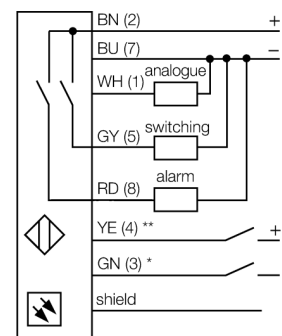

Functional principle

The function principle of the L-GAGE is based on optical triangulation. The emitter and the optics create a light source that is directed towards a target. The target reflects the laser beam back to the receiver lens of the sensor, from where it then falls onto the position sensitive device (PSD) as the receiving element. The target's distance from the receiver determines the angle at which the light meets the receiver element. The integrated microprocessor uses this angle to analyse the target position and to create a corresponding output signal.

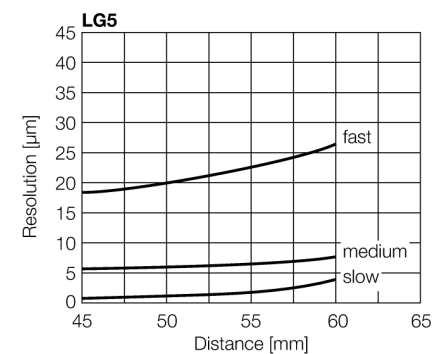

Type code	LG5A65PI
Ident no.	3054089
Operating mode	Diffuse mode laser sensor (triangulation)
Light type	red
Wavelength	670 nm
Focal distance	70 mm
Laser class	△ 2
Repeatability	0.003 mm
Range	45...60 mm
Ambient temperature	-10...+50 °C
Operating voltage	12...30VDC
Residual ripple	< 10 % U _s
DC rated operational current	≤ 100 mA
No-load current I ₀	≤ 50 mA
Short-circuit protection	yes
Reverse polarity protection	yes
Output function	NO contact, PNP/analog output
Current output	4...20mA
Load resistance	≤ 1000 Ω
Switching frequency	≤ 500 Hz
Readiness delay	≤ 1.25 s
Design	rectangular, LG5
Dimensions	82.3 x 20.2 x 55.3 mm
Housing material	metal, ZN, black lacquer
Lens	plastic, acrylic
Connection	cable, PVC
Cable length	2 m
Cable cross section	8 x 0.34 mm ²
Protection class	IP67
Power-on indication	LED green
Switching state	LED yellow

**Photoelectric sensor
laser measuring system
LG5A65PI**

TURCK

Industrial
Automation

Accessories

Type code	Ident no.	Description	Dimension drawing
SMBLG	3055815	Montagewinkel, Edelstahl 304, für Sensoren der Reihe LG5 und LG10	
SMBLGA	3055906	Montagewinkel, Edelstahl 304, für Sensoren der Reihe LG5 und LG10, mit Verstellerschrauben für präzisere Montage	