

czujnik fotoelektryczny triangulation sensor with analog output Q50BIQ

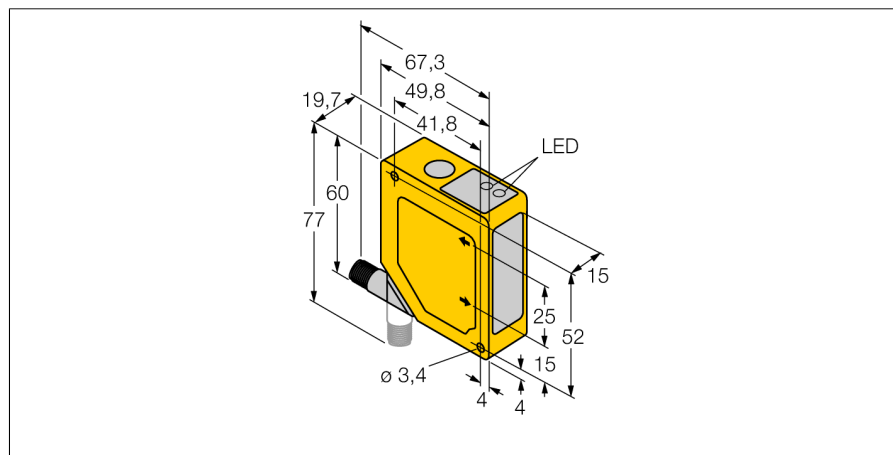

- Foreground and background suppression
- Operating range 100...400 mm
- M12 x 1 connector rotatable by 90°
- Operating voltage 15...30 VDC
- Analog current output 4...20 mA
- selectable output response of 4 ms (fast) and 64 ms (slow)

Schemat podłączenia

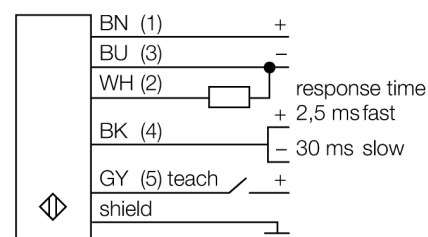

Zasada działania

The function principle of the Q50 is based on optical triangulation. The emitter and the optics create a light source that is directed towards a target. The target reflects the light back to the receiver lens of the sensor, from where it then falls onto the position sensitive device (PSD). The target's distance from the receiver determines the angle at which the light meets the receiver element. The integrated microprocessor uses this angle to analyse the target position and to create a corresponding output signal.

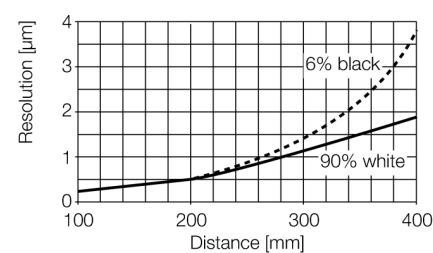

Typ	Q50BIQ
Nr kat.	3063866
Tryb pracy	Czujnik odbiciowy z ustawianym odcięciem tła i przedpola
Rodzaj światła	IR
Długość fali	880 nm
Repeatability	1 mm
Max zakres wykrywania	100...400 mm
Temperatura pracy	-10...+55 °C
Napięcie zasilania	15...30VDC
Prąd bez obciążenia I ₀	≤ 70 mA
wyjście prądowe	4...20mA
Opóźnienie załączenia	≤ 2 s
Wykonanie	prostokątnościenna, Q50
Wymiary	49.8 x 19.7 x 60 mm
Materiał obudowy	tworzywo sztuczne, ABS
Soczewka	tworzywo sztuczne, acrylic
Podłączenie	złącze
Stopień ochrony	IP67