

**Photoelectric sensor
triangulation sensor with analog output
Q50AU**

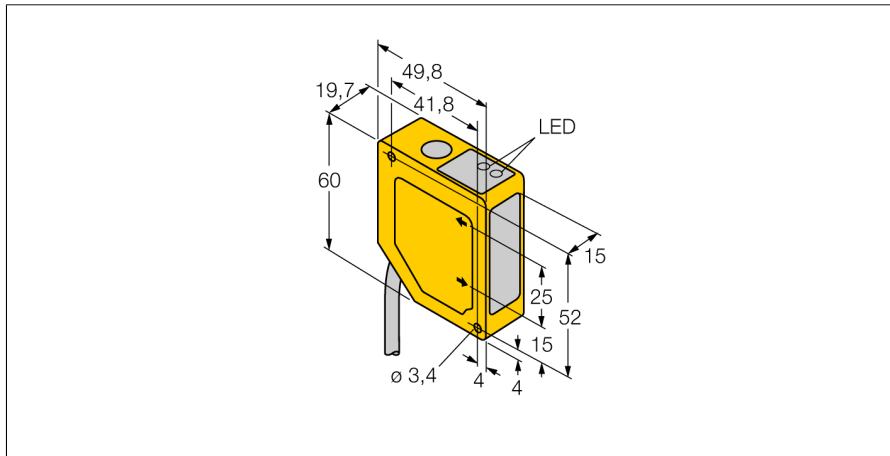

- **Foreground and background suppression**
- **Operating range 50...200 mm**
- **2 m cable, 5-pole**
- **Operating voltage 15...30 VDC**
- **analog voltage output 0...10 V**
- **selectable output response of 4 ms (fast) and 64 ms (slow)**

Wiring diagram

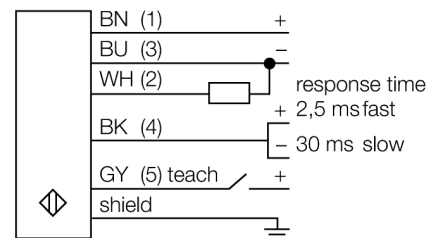

Functional principle

The function principle of the Q50 is based on optical triangulation. The emitter and the optics create a light source that is directed towards a target. The target reflects the light back to the receiver lens of the sensor, from where it then falls onto the position sensitive device (PSD). The target's distance from the receiver determines the angle at which the light meets the receiver element. The integrated microprocessor uses this angle to analyse the target position and to create a corresponding output signal.

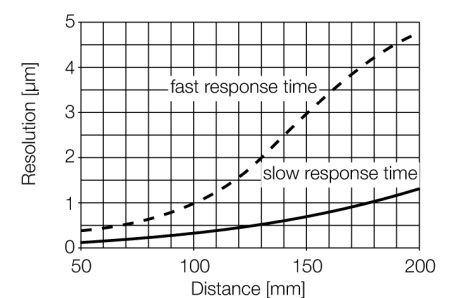

Type code	Q50AU
Ident no.	3067606
Operating mode	Diffuse mode sensor with adjustable foreground and background suppression
Light type	IR
Wavelength	880 nm
Repeatability	0.5 mm
Range	50...200 mm
Ambient temperature	-10...+55 °C
Operating voltage	15...30VDC
No-load current I ₀	≤ 70 mA
Voltage output	0...10V
Readiness delay	≤ 2 s
Design	rectangular, Q50
Dimensions	49.8 x 19.7 x 60 mm
Housing material	plastic, ABS
Lens	plastic, acrylic
Connection	cable
Cable length	2 m
Cable cross section	5 x 0.5 mm ²
Protection class	IP67