

**Photoelectric sensor
retroreflective sensor with polarizing filter
Q85BB62LP-T9-B**

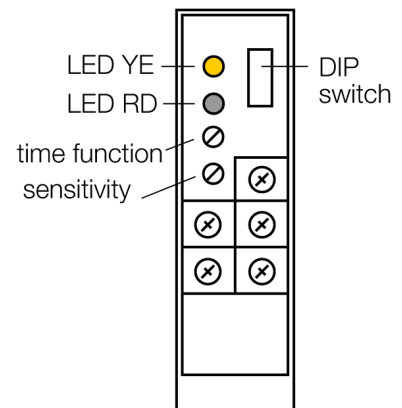

- Integrated terminal chamber
- Cable glands, offset installation by 90° in two places
- Protection class IP67
- AID alignment aid
- Operating voltage: 10...48 VDC
- Outputs: 1 x PNP, 1 x NPN
- Light and dark operation
- Sensitivity adjusted via potentiometer
- Different time functions available, (0.1... 5 s)

Wiring diagram

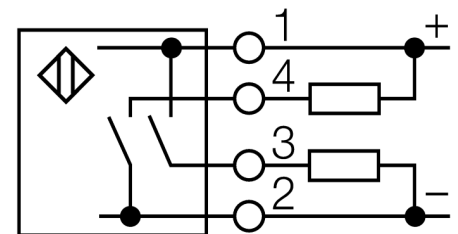

Type code	Q85BB62LP-T9-B
Ident no.	3034256
Operating mode	retro-reflective sensor with polarisation filter
Light type	red
Wavelength	680 nm
Range	80...4600 mm
Ambient temperature	-25...+55 °C
Operating voltage	10...48VDC
DC rated operational current	≤ 120 mA
No-load current I ₀	≤ 50 mA
Short-circuit protection	yes/ cyclic
Reverse polarity protection	yes
Output function	NO contact, PNP/NPN
Switching frequency	0.06 kHz
Switching frequency	≤ 60 Hz
Readiness delay	≤ 100 ms
Overcurrent release	> 270 mA
Design	rectangular, Q85
Dimensions	85 x 65 x 25 mm
Housing material	plastic, ABS, yellow
Lens	acrylic, Plastic
Connection	terminal chamber
Protection class	IP67
Switching state	LED yellow
Excess gain indication	LED red flashing

Functional principle

Retro-reflective sensors incorporate emitter and receiver in a single compact housing. The light beam of the emitter is directed towards a reflector which returns the light back to the receiver. An object is detected when it interrupts this beam. Retro-reflective sensors incorporate some of the advantages of opposed mode sensors (good contrast and high excess gain). Further it is merely required to install and wire a single device. A smaller sensing range and susceptibility of devices without polarisation filter can be of disadvantage when shiny objects have to be detected.

Excess gain curve

Excess gain in relation to the distance

Photoelectric sensor
retroreflective sensor with polarizing filter
Q85BB62LP-T9-B

TURCK

Industrial
Automation

