

**Photoelectric sensor
retroreflective sensor with polarizing filter
miniature sensor
Q12AB6LPQ**

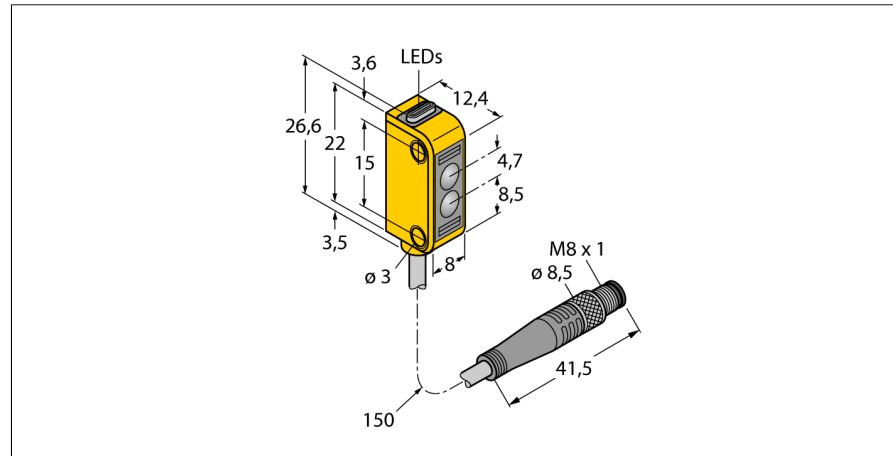

- Cable with male end, 4-pin, PVC, 150 mm, 8 mm
- Protection class IP67
- LED all-round visible
- Indication of insufficient excess gain
- Glass lens
- Operating voltage: 10...30 VDC
- Switching output, bipolar, light operation

Wiring diagram

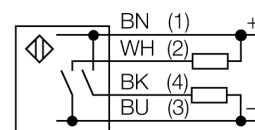

Type code	Q12AB6LPQ
Ident no.	3072129
Operating mode	retro-reflective sensor with polarisation filter
Light type	red
Wavelength	640 nm
Range	100...1000 mm
Ambient temperature	-20...+55 °C
Operating voltage	10...30VDC
Residual ripple	< 10 % U _s
DC rated operational current	≤ 50 mA
No-load current I ₀	≤ 20 mA
Short-circuit protection	yes
Reverse polarity protection	yes
Output function	NO, light operation, PNP/NPN
Switching frequency	≤ 700 Hz
Readiness delay	≤ 120 ms
Design	rectangular, Q12
Dimensions	12.4 x 8 x 26.6 mm
Housing material	plastic, Elastomere, yellow
Lens	glass
Connection	cable with connector, PVC, M8 x 1
Cable length	0.15 m
Cable cross section	4 x 0.34 mm ²
Protection class	IP67
MTTF	135 years acc. to SN 29500 (Ed. 99) 40 °C
Power-on indication	LED green
Switching state	LED yellow
Error indication	LED green
Excess gain indication	LED yellow flashing

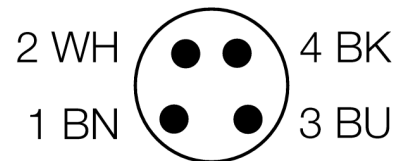

Functional principle

Retro-reflective sensors incorporate emitter and receiver in a single compact housing. The light beam of the emitter is directed towards a reflector which returns the light back to the receiver. An object is detected when it interrupts this beam. Retro-reflective sensors incorporate some of the advantages of opposed mode sensors (good contrast and high excess gain). Further it is merely required to install and wire a single device. A smaller sensing range and susceptibility of devices without polarisation filter can be of disadvantage when shiny objects have to be detected.

Excess gain curve

Excess gain in relation to the distance

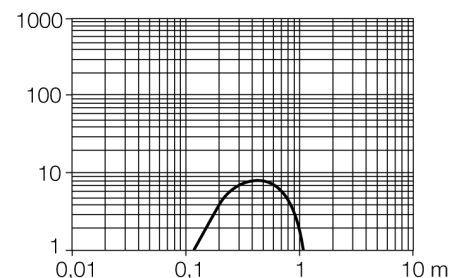

**Photoelectric sensor
retroreflective sensor with polarizing filter
miniature sensor
Q12AB6LPQ**

Accessories

Type code	Ident no.	Description	Dimension drawing
SMBQ12A	3074341	Mounting bracket; material VA 1.4401, for photoelectric sensor, Q12 series	
SMBQ12T	3073722	Mounting bracket; material VA 1.4401, for photoelectric sensor, Q12 series	

Wiring accessories

Type code	Ident no.	Description	Dimension drawing
PKG4M-2/TEL	6625061	Connection cable, female M8, straight, 4-pin, cable length: 2 m, sheath material: PVC, black; cULus approval; other cable lengths and qualities available, see www.turck.com	
PKW4M-2/TEL	6625067	Connection cable, female M8, angled, 4-pin, cable length: 2 m, sheath material: PVC, black; cULus approval; other cable lengths and qualities available, see www.turck.com	

**Photoelectric sensor
retroreflective sensor with polarizing filter
miniature sensor
Q12AB6LPQ**

Function accessories

Type code	Ident no.	Description	Dimension drawing
BRT-60X40C	3044997	Rectangular reflector, reflection coefficient 1.48, material: acrylic, ambient temperature -20...+60 °C	