

**Photoelectric sensor  
retroreflective laser sensor  
PD45VP6LLPQ**

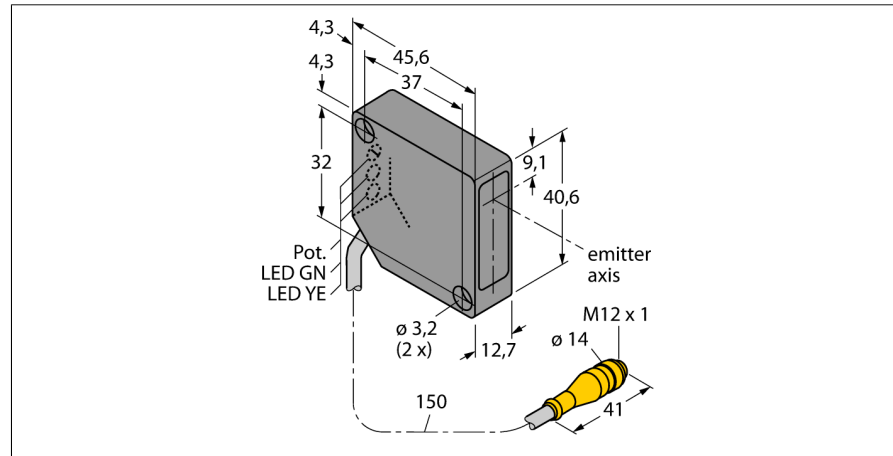

- Laser sensors with high excess gain
- Range 10.6 m
- BRT-36X40BM reflector included in delivery
- M12 x 1 male connector
- Sensitivity adjustable via potentiometer
- Light and dark operation

**Wiring diagram**

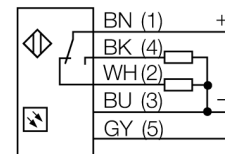

<b>Type code</b>	PD45VP6LLPQ
Ident no.	3058622
<b>Operating mode</b>	Retroreflective laser sensor (triangulation) with polarizing filter
Light type	red
Wavelength	670 nm
Laser class	△ 2
Range	200...10600 mm
Ambient temperature	-10...+45 °C
<b>Operating voltage</b>	10...30VDC
No-load current I <sub>0</sub>	≤ 20 mA
Output function	changover contact, PNP
Switching frequency	2.5 kHz
Readiness delay	≤ 1 s
Overcurrent release	> 220 mA
<b>Design</b>	rectangular, PicoDot
Dimensions	45.6 x 12.7 x 40.6 mm
Housing material	plastic, ABS
Lens	plastic, acrylic
Connection	cable with connector, M12 x 1
Protection class	IP54
<b>Power-on indication</b>	LED green
Switching state	LED yellow
Error indication	LED green flashing

**Functional principle**

Retro-reflective sensors incorporate emitter and receiver in a single compact housing. The light beam of the emitter is directed towards a reflector which returns the light back to the receiver. An object is detected when it interrupts this beam. Retro-reflective sensors incorporate some of the advantages of opposed mode sensors (good contrast and high excess gain). Further it is merely required to install and wire a single device. A smaller sensing range and susceptibility of devices without polarisation filter can be of disadvantage when shiny objects have to be detected.

**Excess gain curve**

Excess gain in relation to the distance

