

Vision systems
camera with integrated analysis
P4ER



- Edge and object detection functions for determination of height, width, position and edges.
- High-speed inspection of more than 10,000 parts per minute.
- 1/5" CMOS, 128x100 pixels
- 256 gray scale values
- One-piece design with camera and integrated controller
- Lens connection vertical to longitudinal axis of housing
- protection class IP20
- Lens to be ordered separately
- Operating voltage: 10...30 VDC via M12 x 1 male, 12-pole
- External trigger input
- External strobe output, M8x1, 3-pole
- EtherNet/IP and Modbus TCP interface via RJ45
- RS232 data communication
- Coaxial BNC video connection cable

Type code	P4ER
Ident no.	3073599
Design	rectangular, P4
Dimensions	124.5 x 66.8 x 34.3 mm
Housing material	aluminium
Connection	male, M12 x 1, 12-wire
Protection class	IP20
Ambient temperature	0...+50 °C
Power on display	LED, green
Switching state	LED green
Error indication	LED red
Operating voltage	10...30VDC
DC rated operational current	≤ 650 mA
Switch element function	NO contact, PNP/NPN
Output current	≥ 150 mA
Operating mode	EDGE
Auflösung	128 x 100 Pixel

Wiring diagram

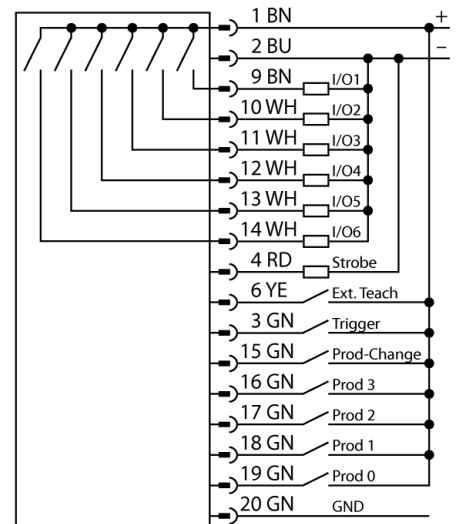

Functional principle

The camera system PresencePLUS P4 consists of a camera with an integrated processing unit. Lens, lighting and connection cable are to be ordered separately. Freeware and firmware updates are available for download on:

www.bannerengineering.com

Vision systems
camera with integrated analysis
P4ER

TURCK

Industrial
Automation

Wiring accessories

Type code	Ident no.	Description	Dimension drawing
P4C06	3073491	Power supply, M12x1 female, 12-pole, 1.83m	
BNC06	3067458	Coaxial BNC connection cable, 1.83 m	
STP07	3069985	RJ45 Ethernet data cable, 2.13m	