

**Draw-Wire**  
**DW6000-155-7E-H1141**

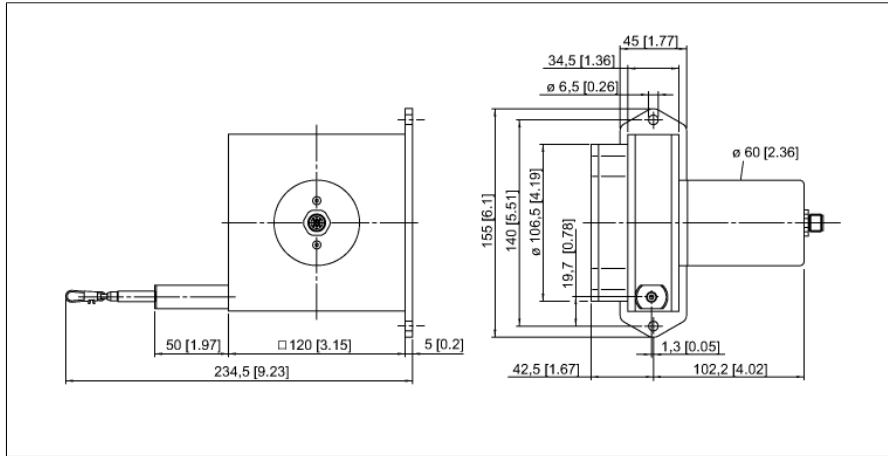

- Measuring range up to 6000mm
- M12 connector
- Protection class: IP65
- Analog output, 4...20 mA
- Supply voltage 12...30 VDC

|   |                |   |
|---|----------------|---|
| 1 | U <sub>B</sub> | + |
| 2 | n.c.           |   |
| 3 | analog out     |   |
| 4 | n.c.           |   |

|                                |                              |
|--------------------------------|------------------------------|
| <b>Type code</b>               | DW6000-155-7E-H1141          |
| Ident no.                      | 1544549                      |
| <b>Measuring range [A...B]</b> | 6000mm                       |
| Linearity deviation            | ≤ 0.1 %                      |
| Ambient temperature            | -20...+60 °C                 |
| <b>Operating voltage</b>       | 12...30VDC                   |
| DC rated operational current   | ≤ 50 mA                      |
| Short-circuit protection       | yes                          |
| Output function                | 2-wire, analog output        |
| Current output                 | 4...20mA                     |
| <b>Housing material</b>        | aluminium, titanium anodized |
| min. extension force           | 8.8 N                        |
| max. extension force           | 12.3 N                       |
| max. extension speed           | 10 m/s                       |
| max. extension speed           | 140 m/s <sup>2</sup>         |
| wire material                  | Stainless steel              |
| Connection                     | male, M12 x 1                |
| Protection class               | IP65                         |

**Draw-Wire**  
**DW6000-155-7E-H1141**

**Pin configuration**

|                                |                 |   |                   |   |   |   |   |   |   |
|--------------------------------|-----------------|---|-------------------|---|---|---|---|---|---|
| <b>Signal</b>                  | +U <sub>s</sub> | - | <b>Analog out</b> | - | - | - | - | - | - |
| <b>Pin configura-<br/>tion</b> | 1               | 2 | 3                 | 4 | - | - | - | - | - |

**Draw-Wire**  
**DW6000-155-7E-H1141**

**TURCK**

Industrial  
Automation

**Accessories**

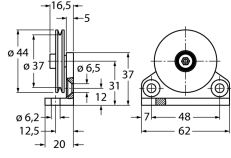
| Type code | Ident no. | Description                                       | Dimension drawing   |
|-----------|-----------|---|---|
| RDR-1     | 1544753   | Deflection roller for aluminium draw-wire sensors |  |