

**Mounting accessories
for linear position sensors
MN-M4-Q25**

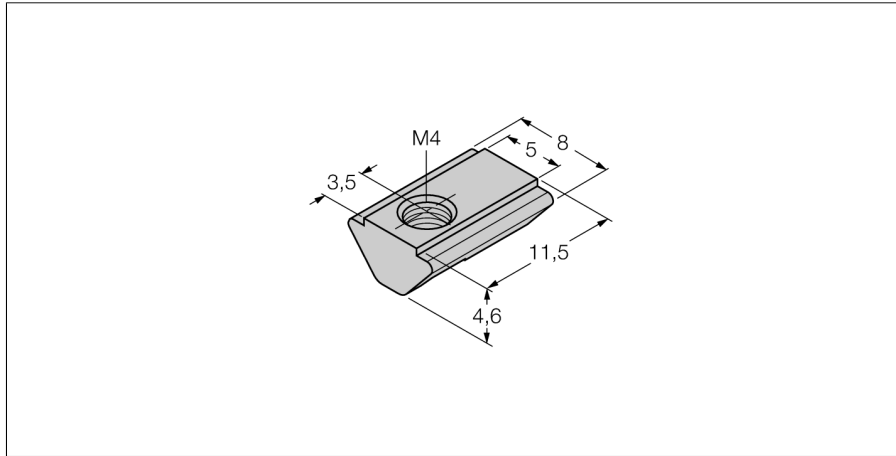

- Sliding blocks for linear position sensors Q25L
- M4 female thread
- Packaging unit: 10 pcs.

General description

The sensor programme comprises inductive, magnetic-inductive, capacitive, photoelectric and ultrasonic sensors as well as pressure and flow controls.

A broad range of practice-oriented accessories ensure optimal adaption to your system.

Type code	MN-M4-Q25
Ident no.	6901025
Design	accessories for rectangular types