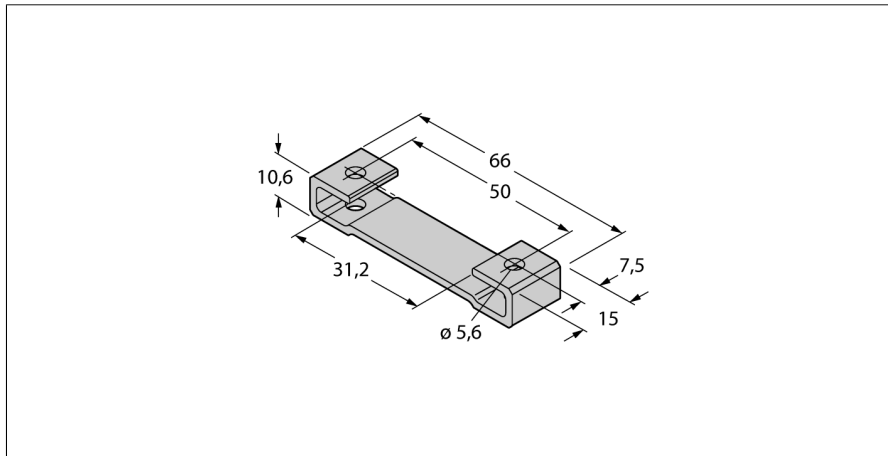

**Mounting bracket
for linear position sensors Li-Q25L
M1-Q25L**

- Mounting foot for linear position sensors Q25L
- Anodized aluminium
- Packaging unit: 2 pcs.
- Recommended torque: 3 Nm

Type code	M1-Q25L
Ident no.	6901045

Dimensions	68.1 x 15.2 x 10 mm
------------	---------------------