

Rotative measurement
Absolute rotary encoder / single-turn
RS-06S6S-8B12B-C 1M

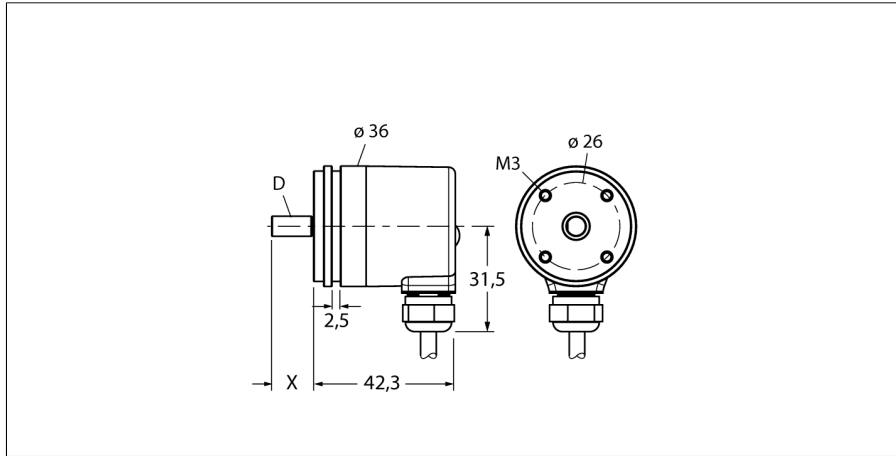

- Synchro flange, Ø 36mm
- Solid shaft with flat, Ø 6 mm x 12.5 mm
- Magnetic measuring principle
- Shaft material, stainless steel
- Protection class IP69K on the shaft side
- -40...+85°C
- max. 6000 rev/min
- 15...30 VDC
- Cable connection, 5-pole
- Analog output, 0...10V
- 360° transferred into 12 bit (4096 positions)

Type code	RS-06S6S-8B12B-C 1M
Ident no.	1544039
Measuring principle	Magnetic
max. Drehzahl	6.000 U/min
Starting torque	0.06 Nm
Measuring range	0...360°
Ambient temperature	-40...+85 °C
Operating voltage	15...30VDC
No-load current I ₀	≤ 35 mA
Short-circuit protection	yes
Output function	5-wire, analog output, 0...10V
Output type	absolute singleturn
Resolution single-turn	12 Bit
Design	Solid shaft
Flange type	Synchro flange
Flange diameter	36 mm
Shaft type	Shaft
Shaft diameter D	6 mm
Shaft length X	12.5 mm
	Shaft with flat
Shaft material	Stainless steel
Housing material	zinc, die-casting
Connection	cable
	radial
cable length	1 m
Axial shaft load	20 N
Radial shaft load	40 N
Vibration resistance (EN 60068-2-6)	10 ... 2000 Hz, 300 m/s ² - rms
Shock resistance (EN 60068-2-27)	5000 m/s ² , 6 ms
Protection class housing	IP69k
Protection class shaft	IP69k

WH	GND
BN	U _B +
GN	analog out
YE	analog GND

Rotative measurement
Absolute rotary encoder / single-turn
RS-06S6S-8B12B-C 1M

Pin configuration

Signal	Gnd	+U _e	Analog out	Analog Gnd	-	-	-	-	-
Core color	WH	BN	GN	YE	-	-	-	-	-

Rotative measurement
Absolute rotary encoder / single-turn
RS-06S6S-8B12B-C 1M

Accessories

Type code	Ident no.	Description	Dimension drawing
RMW-1	1544643	Spring arm for encoders; max. contact pressure 40 N; for encoders with measuring wheel	
RMW-2	1544644	Aluminium measuring wheel (cross-knurled) for encoders, perimeter 0.2 m, width 12 mm, depth 10 mm	
RMW-3	1544645	Hytrel measuring wheel (smooth) for encoders, perimeter 0.2 m, width 12 mm, temp.range -10...+50°C, depth 10 mm	
RMW-4	1544646	Hytrel measuring wheel (grooved) for encoders, perimeter 0.2 m, width 12 mm, temp.range -10...+70 °C, depth 10 mm	
RMW-5	1544647	Aluminium measuring wheel (cross-knurled) for encoders, perimeter 0.5 m, width 25 mm, depth 10 mm	

Rotative measurement
Absolute rotary encoder / single-turn
RS-06S6S-8B12B-C 1M

Accessories

Type code	Ident no.	Description	Dimension drawing
RMW-6	1544648	Hytrel measuring wheel (smooth) for encoders, perimeter 0.5 m, width 25 mm, temp.range -10...+50°C, depth 10 mm	
RMW-7	1544649	Vulkollan measuring wheel (smooth) for encoders, perimeter 0.5 m, width 25 mm, temp.range -30...+80°C, depth 10 mm	
RMW-8	1544650	Aluminium measuring wheel with knobby rubber surface for encoders, perimeter 0.5 m, width 25 mm, temp.range -30...+80°C, depth 10 mm	
RMW-9	1544651	Hytrel measuring wheel (grooved) for encoders, perimeter 0.5 m, width 25 mm, temp.range -10...50 °C, depth 10 mm	