

**Rotative measurement
Incremental rotary encoder
Ri-42H25S4-2B5000-12M23**

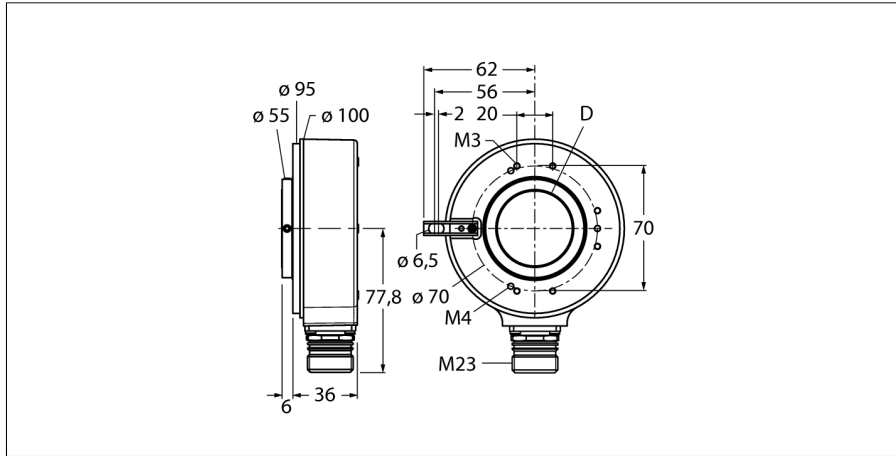

- Flange with long spring element, Ø 100 mm
- Hollow shaft, Ø 25 mm
- Optical measuring principle
- Shaft material, stainless steel
- Protection class IP65 on the shaft side
- -40...+70°C
- max. 3000 rev/min
- 10...30 VDC
- Male connector, M23 x 1, 12-pole
- Push-pull, with inversion
- Pulse frequency max. 300 kHz
- 5000 pulses

Type code	Ri-42H25S4-2B5000-12M23
Ident no.	1545227
Measuring principle	Photoelectric
max. Drehzahl	3.000 U/min
Moment of inertia of the rotor	150 x10 ⁻⁶ kgm ²
Starting torque	0.2 Nm
Ambient temperature	-40...+90 °C
Operating voltage	10...30VDC
No-load current I ₀	≤ 150 mA
Output current	≤ 30 mA
Short-circuit protection	yes
Output function	8-wire, push-Pull, invertable
Output type	incremental
Resolution, incremental	5000
Pulse frequency max.	300 kHz
Signal level high	min. U _s - 3 V
Signal level low	max. 2.5 V
Design	Hollow shaft
Flange type	Flange with mounting element
Flange diameter	100 mm
Shaft type	Hollow shaft
Shaft diameter D	25 mm
Shaft material	Stainless steel
Housing material	zinc, die-casting
Connection	male, M23, 12-pole radial
Vibration resistance (EN 60068-2-6)	100 m/s ² , 10...2000 Hz
Shock resistance (EN 60068-2-27)	1000 m/s ² , 6 ms
Protection class housing	IP65
Protection class shaft	IP65
Included in scope of supply	Spring element, long

1	B inv.
2	U _B sens +
3	0 -
4	0 inv. -
5	A
6	A inv.
7	n.c.
8	B
9	n.c.
10	GND
11	0V sens
12	U _B +
PH	shield

**Rotative measurement
Incremental rotary encoder
Ri-42H25S4-2B5000-12M23**

Pin configuration

Signal	Gnd	+U _s	A	A inv.	B	B inv.	0	0 inv.	Shield
Pin configuration	10	12	5	6	8	1	3	4	PH
Signal	0V sens	+U _s sens	-	-	-	-	-	-	-
Pin configuration	11	2	-	-	-	-	-	-	-

**Rotative measurement
Incremental rotary encoder
Ri-42H25S4-2B5000-12M23**

Accessories

Type code	Ident no.	Description	Dimension drawing
RME-5	1544616	Stainless steel mounting plate for hollow shaft encoders, reference diameter 149 mm, for applications with axial play	
RME-6	1544617	Stainless steel mounting plate for hollow shaft encoders, reference diameter 104...206 mm, for applications with fixing points on adjustable reference diameter	
RME-10	1544621	Stainless steel spring element for hollow shaft encoders, reference diameter 110 mm, for applications with high axial play	
RME-11	1544622	Stainless steel spring element for hollow shaft encoders, reference diameter 76 mm, for applications with limited mounting space	
RME-15	1544626	Metal arm bracket, for hollow shaft encoders, length 70mm; for applications with little axial and radial play; flexibly adjustable	

**Rotative measurement
Incremental rotary encoder
Ri-42H25S4-2B5000-12M23**

Accessories

Type code	Ident no.	Description	Dimension drawing
RME-16	1544627	Metal arm bracket, for hollow shaft encoders, length 100 mm; for applications with little axial and radial play; flexibly adjustable	
RME-17	1544628	Metal arm bracket, for hollow shaft encoders, length 150mm; for applications with little axial and radial play; flexibly adjustable	
RME-18	1544629	Stainless steel stator coupling for hollow shaft encoders, reference diameter 119 mm, for highly dynamic applications with axial and radial play	