

Inclinometer
B2N360-Q42-E2LiUPN8X2-H1181

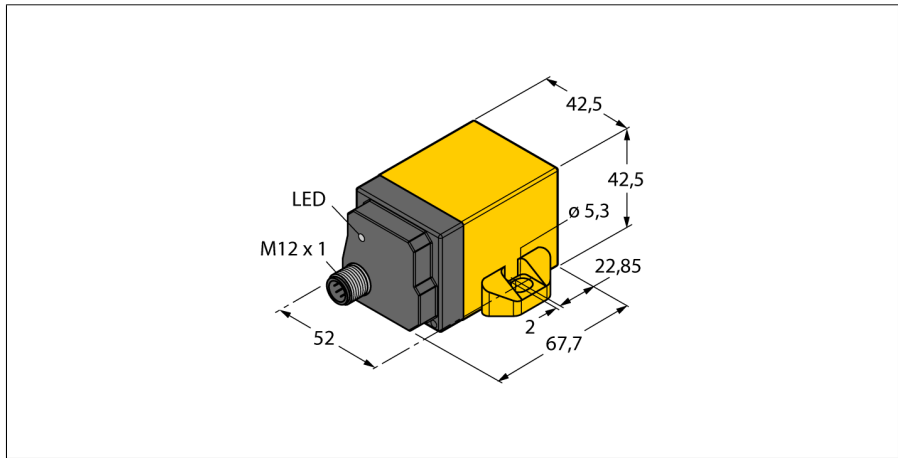

- Rectangular, plastic, PA12-GF30
- Status display via LEDs
- Different filter functions
- Parametrizable via teach pin
- Acceleration function ± 2 g, measuring range parametrizable
- 8-wire, 15...30 VDC
- Analog output
- Parametrizable current and voltage output functions
- Factory setting 4...20 mA
- All functions parametrizable via IO-Link/PACTware
- NC/NO programmable functions, available as NPN or PNP version
- Process value for x and y-axis, provided for each in as 16-bit IO-Link telegram
- Male M12 x 1; 8-pin
- Adapter cable RKC8.301T-1,5-RSC4T/TX320 required for IO-Link communication

Type code	B2N360-Q42-E2LiUPN8X2-H1181
Ident no.	1534116
Resolution	16 bit
Measuring range	0...360°
Measuring range x-axis	0...360°
measuring range y-axis	0...360°
Repeatability	≤ 0.03 % of full scale
	\leq depending on the filter setting
Linearity deviation	≤ 0.2 %
Temperature drift	$\leq \pm 0.015$ % / K
Ambient temperature	-25...+85 °C
Operating voltage	15...30VDC
Residual ripple	≤ 10 % U_{in}
DC rated operational current	≤ 150 mA
Rated insulation voltage	≤ 0.5 kV
Short-circuit protection	yes
Wire breakage / Reverse polarity protection	yes/ complete
Output function	8-wire, NO/NC , PNP/NPN, analog output
Voltage output	0...10V
Current output	0...20mA
	parametrizable via IO-Link, e.g. 4...20 mA
Load resistance voltage output	≥ 4.7 k Ω
Load resistance current output	≤ 0.4 k Ω
Sample rate	500 Hz
Communication	IO-Link specified acc. to version 1.0
Parameterization	FDT/DTM
Transmission rate	COM 2 / 38.4 kbps
Frame type	2.2
Design	rectangular, Q42
Dimensions	67.5 x 42.5 x 42.5 mm
Housing material	plastic, PA
Connection	male, M12 x 1
Vibration resistance	55 Hz (1 mm)
Shock resistance	30 g (11 ms)
Protection class	IP68 / IP69K
MTTF	159 years acc. to SN 29500 (Ed. 99) 40 °C
Power-on indication	LED green
Switching state	LED yellow

Wiring diagram

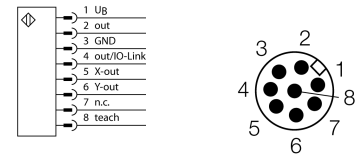

Functional principle

The TURCK inclinometers incorporate a micro-mechanical pendulum, operating on the principle of MEMS technology (Mikro Elektro Mechanic Systems).

The pendulum basically consists of two 'plate' electrodes arranged in parallel with a dielectric placed in the middle. When the sensor is inclined, the dielectric in the middle moves, causing the capacitance ratio between both electrodes to change.

The downstream electronics evaluates this change in capacitance and generates a corresponding output signal.

Inclinometer
B2N360-Q42-E2LiUPN8X2-H1181

TURCK

Industrial
Automation

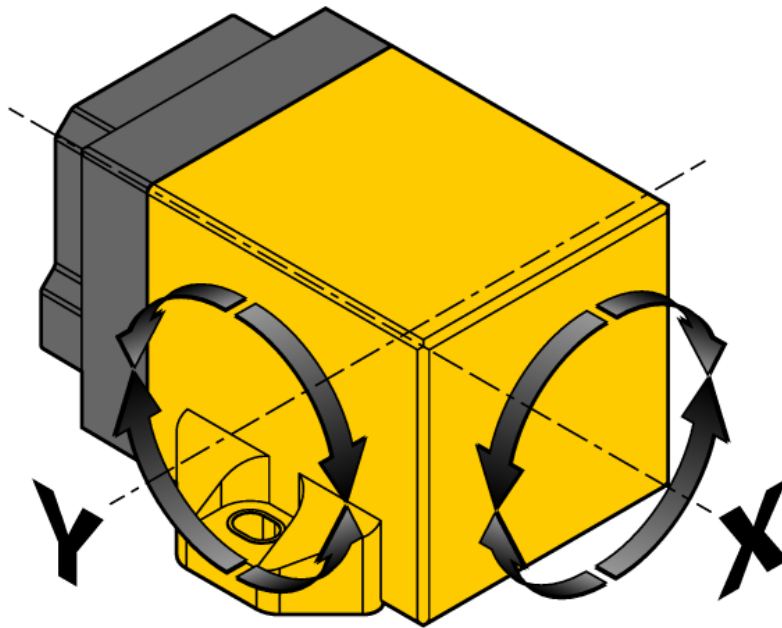

The sensor is able to display any angular value via 2 axes. The drawing on the right shows to which axis, X or Y, the values are assigned to.

The devices can be parametrized via IO-Link or teach pin. (Measuring range, zero point, hysteresis, filter settings). Different analog and digital output values provide highest flexibility in terms of process integration. 4 ... 20 mA, 0 ... 10V, PNP/NPN hysteresis NC or NO programmable, 2 x 16 bit (IO-Link telegram)

Inclinometer

B2N360-Q42-E2LiUPN8X2-H1181

Teaching instructions

Parameters	Teach input	LED
Zero point offset (see notes)	bridge Pin 3 (GND) and Pin 8 for 5 s	Status LED (yellow) flashes, after 1 s steady, after 3 s flashes, after 5 s steady
Measuring range start, X-axis (see notes)	Bridge Pin 1 (U _s) and Pin 8 for 1 s	Status LED (green) flashes, after 1 s steady
Measuring range end, X-axis (see notes)	bridge Pin 1 (U _s) and Pin 8 for 3 s	Status LED (green) flashes, after 1 s steady, after 3 s flashes
Measuring range start, Y-axis (see notes)	Bridge Pin 3 (GND) and Pin 8 for 1 s	Status LED (yellow) flashes, after 1 s steady
Measuring range end, Y-axis (see notes)	bridge Pin 3 (GND) and Pin 8 for 3 s	Status LED (yellow) flashes, after 1 s steady, after 3 s flashes
Pre-set mode Angle	Bridge Pin 1 (U _s) and Pin 8 for 10 s You must set a further teach input within 10 s or the device exits this mode automatically	Status LED (green) flashes, after 10 s steady
-10° ... +10°	bridge Pin 3 (GND) and Pin 8 once briefly	LED (yellow) flashes once
-45° ... +45°	bridge Pin 3 (GND) and Pin 8 twice briefly	LED (yellow) flashes twice
-60° ... +60°	bridge Pin 3 (GND) and Pin 8 three times briefly	LED (yellow) flashes three times
-85° ... +85°	bridge Pin 3 (GND) and Pin 8 four times briefly	LED (yellow) flashes four times
Pre-set mode Function	Bridge Pin 1 (U _s) and Pin 8 for 10 s You must set a further teach input within 10 s or the device exits this mode automatically	Status LED (green) steady, after 10 s flashes
Mode 1 "upper hemisphere", default setting	Bridge Pin 1 (U _s) and Pin 8 once briefly	LED (green) flashes once
Mode 2 "lower hemisphere"	Bridge Pin 1 (U _s) and Pin 8 twice briefly	LED (green) flashes twice
Mode 3, 2 x 360°	Bridge Pin 1 (U _s) and Pin 8 three times briefly	LED (green) flashes three times
Mode 4, X: 0...360°, Y: off	Bridge Pin 1 (U _s) and Pin 8 four times briefly	LED (green) flashes four times
Mode 5, Y: 0...360°, X: off	Bridge Pin 1 (U _s) and Pin 8 five times briefly	LED (green) flashes five times
Filter setting mode	Bridge Pin 3 (GND) and Pin 8 for 10 s You must set a further teach input within 10 s or the device exits this mode automatically	Status LED (yellow) steady, after 10 s flashes
24 Hz, default setting	bridge Pin 3 (GND) and Pin 8 once briefly	LED (yellow) flashes once
15 Hz	bridge Pin 3 (GND) and Pin 8 twice briefly	LED (yellow) flashes twice
Most effective filter setting	bridge Pin 3 (GND) and Pin 8 three times briefly	LED (yellow) flashes three times
Default setting	Bridge Pin 3 (GND) or Pin 1 (UB) and Pin 8 for 15 s	LED flashes fast after 15 s

Note:

Please note that with changing the zero point you also change the start and end point of the measuring range accordingly. Furthermore, it is not possible to offset the zero-point in the "upper hemisphere" and "lower hemisphere" mode, since this would cause the measuring range to partially exceed the defined spread of 0°...±90° or rather 90°... 270°.

This must also be observed when parametrizing the start and end point.

Inclinometer
B2N360-Q42-E2LiUPN8X2-H1181

Accessories

Type code	Ident no.	Description	Dimension drawing
USB-2-IOL-0002	6825482	IO-Link master with integrated USB port	
RKC8.301T-1,5-RSC4T/ TX320	6625002	Adapter cable to connect sensor to USB-2-IOL-0002 parametrizing unit; female M12, straight, 8-pin on male M12, straight, 3-pin; cable length: 1.5 m; sheath material: PUR, sheath color: black, cULus approved; RoHS conform; protection class IP67	
TX3-Q20L60	6967118	Teach adapter for 8-pin sensors	