

temperature sensors  
infrared sensor  
M18TUP6E

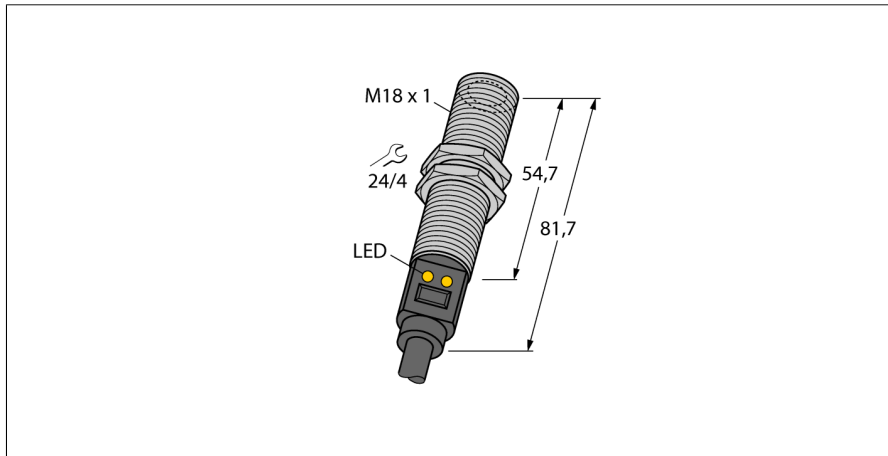

- Connection via cable, 2 m
- D:S ratio 6:1
- Operating voltage 12...30 VDC
- Measuring range adjustable via teach-in
- Analog output 0...10 V
- PNP Alarm output switches at 10 V
- Temperature range 0 ... +300 °C

**Wiring diagram**

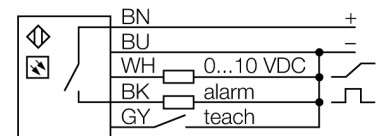

<b>Type code</b>	M18TUP6E
Ident no.	3074918
<b>Operating mode</b>	infrared sensor
Ambient temperature	-20...+70 °C
Temperature range	≥0...≤300 °C
Switching point accuracy	± 0.5 °C
<b>Operating voltage</b>	12...30VDC
Short-circuit protection	yes/ cyclic
Reverse polarity protection	yes
Output function	NO contact, PNP/analog output
Voltage output	0...10V
Readiness delay	≤ 1.5 s
<b>Design</b>	cylindrical/threaded, M18T
Dimensions	81.7 mm
Housing material	stainless steel, V2A (1.4301)
Connection	cable
Cable length	2 m
Cable cross section	5 x 0.5 mm <sup>2</sup>
Protection class	IP67
<b>Power-on indication</b>	LED green
Switching state	LED yellow

**Functional principle**

Temperature sensors are used in applications where temperatures for control and optimization of processes must be captured and monitored. The sensor operates only as a receiver. The thermal radiation of an object within a wave length range of 8 to 14 μm is transformed into an electrical signal via a thermopile and then further processed to become an output signal. Here the D:S (distance: spot) ratio is very important because it specifies the diameter of the spot at a defined distance. The sensor is optimally aligned, if the spot is completely covered by the object, whose temperature is to be monitored.

**D:S ratio**

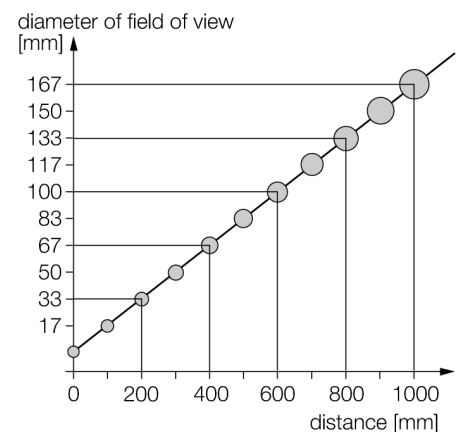

temperature sensors  
infrared sensor  
M18TUP6E

**Accessories**

Type code	Ident no.	Description	Dimension drawing
SMB18A	3033200	Mounting bracket, stainless steel, for sensors with 18 mm thread	
SMB18SF	3052519	Mounting bracket, PTB black steel, for sensors with 18 mm thread	
SMB18UR	3052517	Mounting bracket, for wall mounting, stainless steel 300, 2-piece, rotatable, 18 mm bore hole, screw set included	
LAT1812	3074262	Laser alignment aid, visible red, contains M12 laser emitter (laser class 2) and mounting bracket SMB1812, for sensors with 18 mm thread, 10 ... 30 VDC supply necessary	