



CONTACTOR 3-PH 11 KW / 400 V,
220 V AC 60 HZ, 3-POLE, SIZE S0,
SCREW CONNECTION

General technical data:

product brand name		SIRIUS
Size of the contactor		S0
Protection class IP / on the front		IP20
Degree of pollution		3
Installation altitude / at a height over sea level / maximum	m	2,000
Ambient temperature / during operating	°C	-25 ... +60
Mechanical operating cycles as operating time		
<ul style="list-style-type: none"> • of the contactor / typical 		10,000,000
<ul style="list-style-type: none"> • of the contactor with added auxiliary switch block / typical 		10,000,000
<ul style="list-style-type: none"> • of the contactor with added electronics-compatible auxiliary switch block / typical 		5,000,000

Main circuit:

Number of NC contacts / for main contacts		0
Number of NO contacts / for main contacts		3
Operating current		
<ul style="list-style-type: none"> • at AC-1 / at 400 V <ul style="list-style-type: none"> • at 40 °C ambient temperature / rated value 	A	40
<ul style="list-style-type: none"> • at AC-3 / at 400 V / rated value 	A	25
<ul style="list-style-type: none"> • at AC-4 / at 400 V / rated value 	A	15.5

• with 1 current path / at DC-1	A	35
• at 24 V / rated value	A	4.5
• at 110 V / rated value		
• with 2 current paths in series / at DC-1	A	35
• at 24 V / rated value	A	35
• at 110 V / rated value		
• with 3 current paths in series / at DC-1	A	35
• at 24 V / rated value	A	35
• at 110 V / rated value		
• with 1 current path / at DC-3 / at DC-5	A	20
• at 24 V / rated value	A	2.5
• at 110 V / rated value		
• with 2 current paths in series / at DC-3 / at DC-5	A	35
• at 24 V / rated value	A	15
• at 110 V / rated value		
• with 3 current paths in series / at DC-3 / at DC-5	A	35
• at 24 V / rated value	A	35
• at 110 V / rated value		
Service power		
• at AC-2 / at 400 V / rated value	kW	11
• at AC-3 / at 400 V / rated value	kW	11
• at AC-4 / at 400 V / rated value	W	7,500

Control circuit:		
Voltage type / of control feed voltage		AC
Operating range factor control supply voltage rated value / of the magnet coil		
• at 60 Hz		
• for AC		0.8 ... 1.1
Apparent pull-in power / of the solenoid / for AC	V·A	69
Apparent holding power / of the solenoid / for AC	V·A	7.5
Inductive power factor / with the pull-in power of the coil		0.76
Inductive power factor / with the pull-in power of the coil		0.28

Auxiliary circuit:		
Contact reliability / of the auxiliary contacts		1 faulty switching per 100 million (17 V, 1 mA)
Number of NC contacts / for auxiliary contacts / instantaneous switching		0
Number of NO contacts / for auxiliary contacts / instantaneous switching		0

Short-circuit:

Design of the fuse link	<ul style="list-style-type: none"> • for short-circuit protection of the auxiliary switch / required 	fuse gL/gG: 10 A
	<ul style="list-style-type: none"> • for short-circuit protection of the main circuit 	fuse gL/gG: 100 A
	<ul style="list-style-type: none"> • with type of assignment 1 / required • at type of coordination 2 / required 	fuse gL/gG: 35 A

Installation/mounting/dimensions:

Mounting type		screw and snap-on mounting onto 35 mm standard mounting rail according to DIN EN 50022
series installation		Yes
Width	mm	45
Height	mm	85
Depth	mm	91
Distance, to be maintained, to earthed part / sideways	mm	6

Connection type:

Design of the electrical connection		<ul style="list-style-type: none"> • for main current circuit • for auxiliary and control current circuit 	<p>screw-type terminals</p> <p>screw-type terminals</p>
Type of the connectable conductor cross-section		<ul style="list-style-type: none"> • for main contacts <ul style="list-style-type: none"> • solid • finely stranded <ul style="list-style-type: none"> • with conductor end processing • for AWG conductors / for main contacts • for auxiliary contacts <ul style="list-style-type: none"> • solid • finely stranded <ul style="list-style-type: none"> • with conductor end processing • for AWG conductors / for auxiliary contacts 	<p>2x (1 ... 2.5 mm²), 2x (2.5 ... 6 mm²), max. 2x 10 mm²</p> <p>2x (1 ... 2.5 mm²), 2x (2.5 ... 6 mm²)</p> <p>2x (20 ... 16), 2x (18 ... 14), 1x 12</p> <p>2x (0.5 ... 1.5 mm²), 2x (0.75 ... 2.5 mm²), max. 2x (0.75 ... 4 mm²)</p> <p>2x (0.5 ... 1.5 mm²), 2x (0.75 ... 2.5 mm²)</p> <p>2x (20 ... 16), 2x (18 ... 14), 1x 12</p>

Certificates/approvals:

General Product Approval



Functional Safety / Safety of Machinery

[Type Examination](#)

Declaration of Conformity



Test Certificates

[Special Test Certificate](#)

[Type Test Certificates/Test Report](#)

Shipping Approval



GL



LRS



RINA



RMRS

other

[Confirmation](#)

[other](#)

[Environmental Confirmations](#)

Further information:

Information- and Downloadcenter (Catalogs, Brochures,...)

<http://www.siemens.com/industrial-controls/catalogs>

Industry Mall (Online ordering system)

<http://www.siemens.com/industrial-controls/mall>

Cax online generator:

<http://www.siemens.com/cax>

Service&Support (Manuals, Certificates, Characteristics, FAQs,...)

<http://support.automation.siemens.com/WW/view/en/3RT1026-1AN10/all>

Image database (product images, 2D dimension drawings, 3D models, device circuit diagrams, ...)

http://www.automation.siemens.com/bilddb/cax_en.aspx?mlfb=3RT1026-1AN10

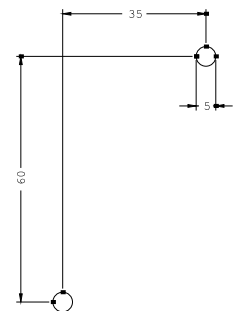
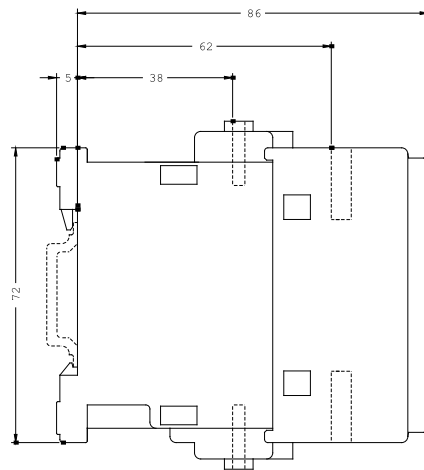
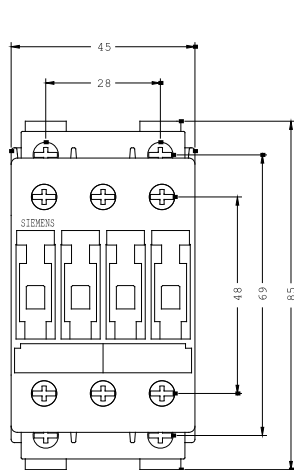

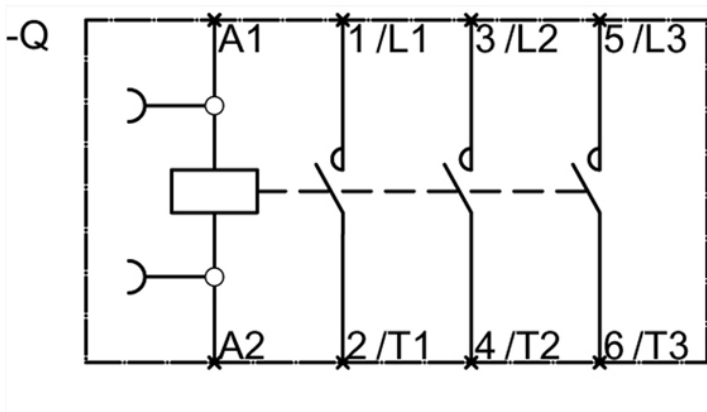

last change:

Jul 28, 2014