

Flow sensor
Immersion sensor with integrated processor
FCS-GL1/2A2P-VRX/230VAC/A

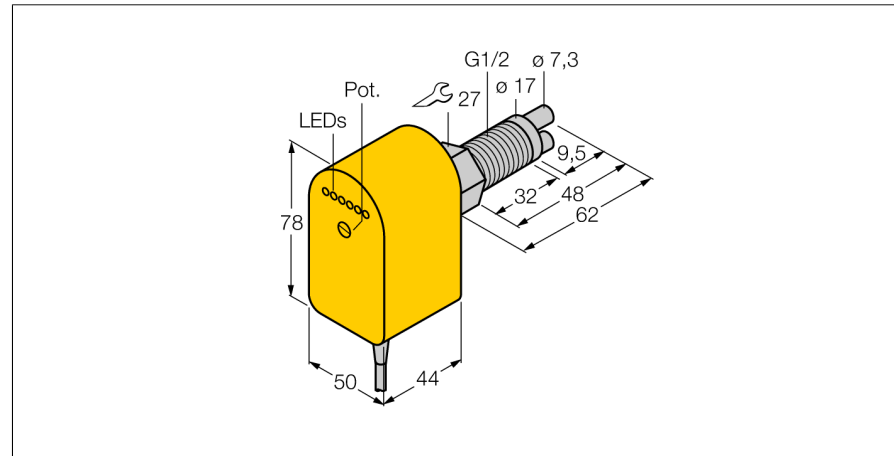

- Sensor for gaseous media
- Calorimetric principle
- Adjustments via potentiometer
- AC 5-wire, 195...264 VAC
- Changeover contact, relay output
- Cable device

Wiring diagram

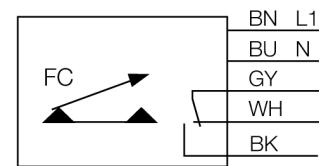

Functional principle

Our insertion - flow sensors operate on the principle of thermodynamics. The measuring probe is heated by several °C as against the flow medium. When fluid moves along the probe, the heat generated in the probe is dissipated. The resulting temperature is measured and compared to the medium temperature. The flow status of every medium can be derived from the evaluated temperature difference. Thus TURCK's wear-free flow sensors reliably monitor the flow of gaseous and liquid media.

| | |
|------------------------------------|---------------------------------|
| Type code | FCS-GL1/2A2P-VRX/230VAC/A |
| Ident no. | 6870458 |
| Air operating range | 0.5...30 m/s |
| Stand-by time | 10...90 s |
| Switch-on time | 2...30 s |
| Switch-off time | 5...30 s |
| Temperature gradient | ≤ 20 K/min |
| Medium temperature | - 20...80 °C |
| Operating voltage | 195...264 VAC |
| No-load current I ₀ | ≤ 30 mA |
| Output function | Relay output, changover contact |
| Rated operational current | 4 A |
| Short-circuit protection | no |
| AC switching voltage | 250 VAC |
| DC switching voltage | 60 VDC |
| Max. AC switching capacity | 1000 VA |
| Max. DC switching capacity | 60 W |
| Housing material | plastic, PBT |
| Sensor material | stainless steel, AISI 303 |
| Max. tightening torque housing nut | 100 Nm |
| Connection | cable |
| Cable length | 2 m |
| Cable cross section | 5 x 0.5 mm ² |
| Pressure resistance | 30 bar |
| Process connection | G ½" long |
| Switching state | LED chain green / yellow / red |
| Flow state display | LED chain, red (1x), green (5x) |
| Indication: Drop below setpoint | LED red |
| Indication: Setpoint reached | LED yellow |
| Indication: Setpoint exceeded | 4 x LEDs green |
| LED display | red = 4 mA |
| | 1 x green > 4 mA |
| | 2 x green > 8 mA |
| | 3 x green > 12 mA |
| | 4 x green > 16 mA |
| | 5 x green = 20 mA |