

**Flow sensor**  
**Immersion sensor with integrated processor**  
**FCS-M18-AP8X**

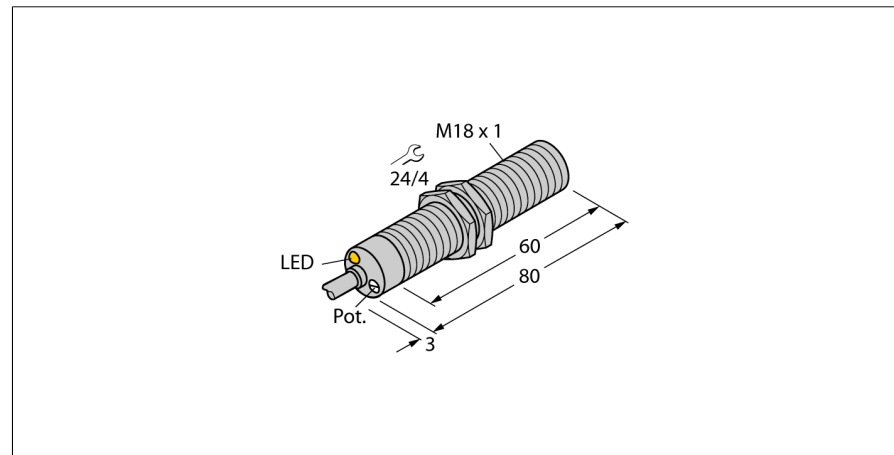

- Flow sensor for gaseous media
- Calorimetric principle
- Adjustment via potentiometer
- Status display via 2-color LED
- Chrome-plated brass sensor
- 3-wire DC, 19.2...28.8 VDC
- NO contact, PNP output
- Cable device

**Wiring diagram**

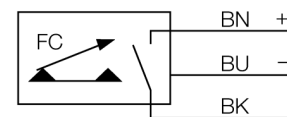

**Functional principle**

Our insertion - flow sensors operate on the principle of thermodynamics. The measuring probe is heated by several °C as against the flow medium. When fluid moves along the probe, the heat generated in the probe is dissipated. The resulting temperature is measured and compared to the medium temperature. The flow status of every medium can be derived from the evaluated temperature difference. Thus TURCK's wear-free flow sensors reliably monitor the flow of gaseous and liquid media.

<b>Type code</b>	FCS-M18-AP8X
Ident no.	6870704
<b>Air operating range</b>	0.5...15 m/s
Switch-on time	typ. 2 s (1...20 s)
Switch-off time	typ. 2 s (1...20 s)
Temperature gradient	≤ 200 K/min
Medium temperature	- 20...70 °C
<b>Operating voltage</b>	19.2...28.8VDC
Output function	PNP, NO contact
Rated operational current	0.4 A
Short-circuit protection	yes
Reverse polarity protection	yes
Protection class	IP67
<b>Housing material</b>	metal, CuZn
Sensor material	brass, brass, nickel-plated
Connection	cable
Cable length	2 m
Cable cross section	3 x 0.5 mm <sup>2</sup>
Pressure resistance	3 bar
Process connection	M18 x 1
<b>Switching state</b>	2-color LED red / green