

Flow sensor
Immersion sensor with integrated processor
FCS-HA2P-VRX/24VDC/AL115 6M

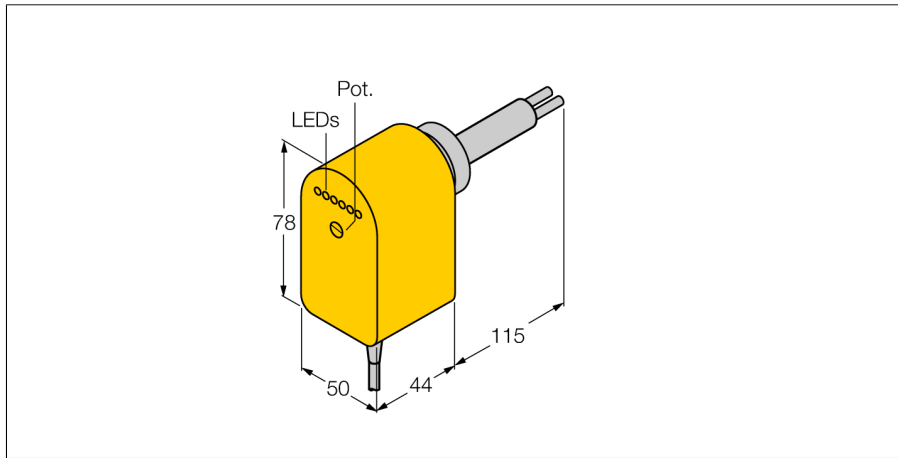

- Sensor for gaseous media
- Calorimetric principle
- Adjustments via potentiometer
- Sensor length 115 mm
- 5-wire DC, 19.2...28.8 VDC
- Changeover contact, relay output
- Cable device

Wiring diagram

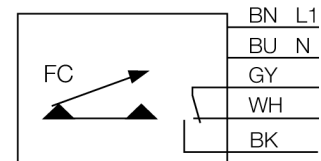

Type code FCS-HA2P-VRX/24VDC/AL115 6M
Ident no. 6870725

Air operating range	0.5...30 m/s
Stand-by time	10...60 s
Switch-on time	2...30 s
Switch-off time	5...30 s
Temperature gradient	≤ 20 K/min
Medium temperature	- 20...80 °C
Operating voltage	19.2...28.8VDC
No-load current I ₀	≤ 80 mA
Output function	Relay output, changover contact
Rated operational current	4 A
Short-circuit protection	no
AC switching voltage	250 VAC
DC switching voltage	60 VDC
Max. AC switching capacity	1000 VA
Max. DC switching capacity	60 W

Functional principle

Our insertion - flow sensors operate on the principle of thermodynamics. The measuring probe is heated by several °C as against the flow medium. When fluid moves along the probe, the heat generated in the probe is dissipated. The resulting temperature is measured and compared to the medium temperature. The flow status of every medium can be derived from the evaluated temperature difference. Thus TURCK's wear-free flow sensors reliably monitor the flow of gaseous and liquid media.

Housing material	plastic, PBT
Sensor material	stainless steel, AISI 303
Max. tightening torque housing nut	100 Nm
Connection	cable
Cable length	6 m
Cable cross section	5 x 0.5 mm ²
Pressure resistance	3 bar
Process connection	G 1" female thread acc. to DIN 3852

Switching state	LED chain green / yellow / red
Flow state display	LED chain, red (1x), green (5x)
Indication: Drop below setpoint	LED red
Indication: Setpoint reached	LED yellow
Indication: Setpoint exceeded	4 x LEDs green
LED display	red = 4 mA
	1 x green > 4 mA
	2 x green > 8 mA
	3 x green > 12 mA
	4 x green > 16 mA
	5 x green = 20 mA