

Flow sensor
Inline sensor with integrated processor
FCI-D06CTP-ARX-H1140

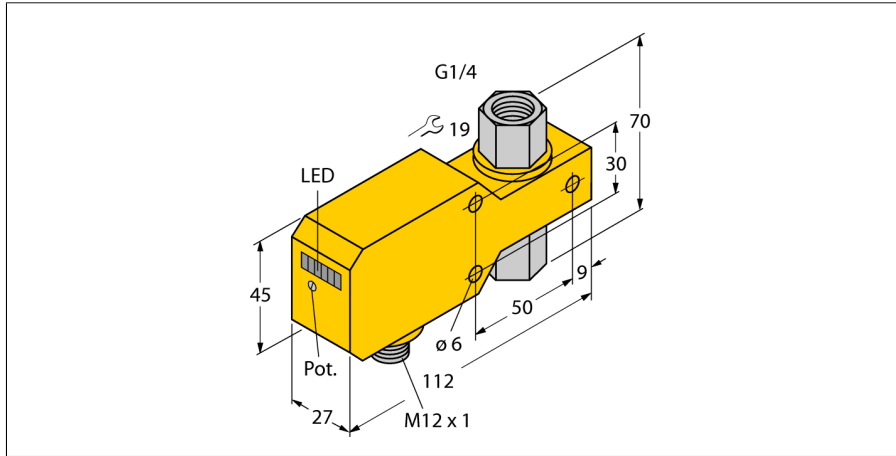

- Flow sensor for liquid media
- Calorimetric principle
- Adjustment via potentiometer
- LED band
- Operating range 0.02...3 l/min
- Sensor material ceramics/plastic
- Seal made of FKM
- 4-wire DC, 21...26 VDC
- NO contact, relay output
- Plug-in device, M12 x 1

Wiring diagram

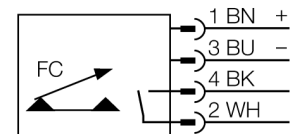

Functional principle

The function of the inline flow sensors is based on the thermo-dynamic principle. Heat is generated in a measuring tube and absorbed by the flowing medium. The transported heat loss is thus a measure of the flow speed. Thus TURCK's wear-free flow sensors reliably monitor the flow of gaseous and liquid media. A low pressure drop and fast response to flow rate variations are the outstanding features of these devices.

Type code	FCI-D06CTP-ARX-H1140
Ident no.	6870625
Flow operating range	0.02...3 l/min.
Stand-by time	5...15 s
Switch-on time	0.5...3 s
Switch-off time	0.5...3 s
Temperature gradient	≤ 400 K/min
Medium temperature	0...60 °C
Ambient temperature	0...60 °C
Operating voltage	21...26VDC
No-load current I ₀	≤ 50 mA
Output function	Relay output, NO contact
Rated operational current	1 A
Short-circuit protection	no
Reverse polarity protection	yes
AC switching voltage	30 VAC
DC switching voltage	36 VDC
Housing material	plastic, PBT
Sensor material	ceramics/plastic, Al ₂ O ₃ /PTFE
Max. tightening torque housing nut	5 Nm
Connection	male, M12 x 1
Pressure resistance	5 bar
Process connection	G 1/4" female thread
Switching state	LED chain green / yellow / red
Flow state display	LED chain, red (1x), green (5x)
Indication: Drop below setpoint	LED red
Indication: Setpoint reached	LED yellow
Indication: Setpoint exceeded	4 x LEDs green
LED display	red = 4 mA
	1 x green > 4 mA
	2 x green > 8 mA
	3 x green > 12 mA
	4 x green > 16 mA
	5 x green = 20 mA