

**Freely rotatable FCST flow sensor
monitoring of flow velocity
relay output 24 VDC NO
FCST-A4P-ARX-H1140**

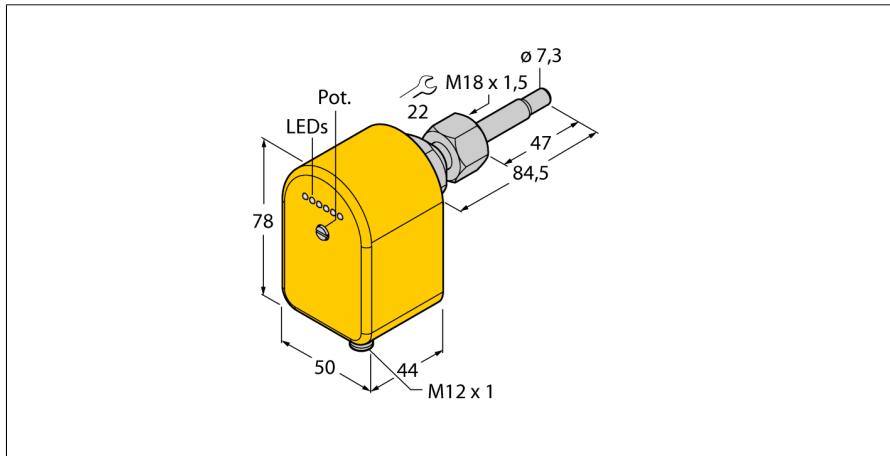

- Thermodynamic operating principle
- Flow monitoring
- Switchpoint freely adjustable
- Adjusted via potentiometer
- LED band for indications
- Relay switching output
- 24 VDC NO
- Switchpoint freely adjustable
- Freely rotatable sensor
- Plugged in with adapter
- Screw-in adapter, M18 x 1.5

Wiring diagram

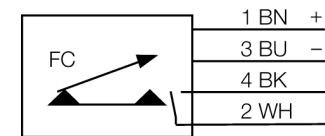

Functional principle

The FCST flow sensors operate on the thermodynamic principle.

Thanks to the modular plug-in concept, they can be aligned freely within the flow channel, independent from the process connection. The modular concept makes installation and precise alignment of the sensor easy which is very important for flow monitoring.

The adapters are available in all standard industrial thread sizes. The sensor-adapter system can thus be adjusted easily to any application requirements. The modular concept makes the system also very resistant to high pressures.

Especially flow sensors with integrated signal processor profit from the modular FCST concept. Thanks to the freely alignable sensor, the LED display is always easy to read and the potentiometers for the adjustment of the switchpoint or analog signal are always within reach.

Type code	FCST-A4P-ARX-H1140
Ident no.	6870252
Operating range water	1...150cm/s
Oil operating range	3...300 cm/s
Stand-by time	typ. 8 s (2...15 s)
Switch-on time	typ. 2 s (1...13 s)
Temperature gradient	≤ 250 K/min
Medium temperature	-20...80 °C
Ambient temperature	-20...70 °C
Operating voltage	19.2...28.8VDC
No-load current I ₀	≤ 100 mA
Output function	Relay output, NO contact
Protection class	IP67
Housing material	plastic, PBT
Sensor material	stainless steel, AISI 316Ti
Seal	FPM
Connection	male, M12 x 1
Pressure resistance	100 bar
Process connection	M18 x 1.5 female thread

**Freely rotatable FCST flow sensor
monitoring of flow velocity
relay output 24 VDC NO
FCST-A4P-ARX-H1140**

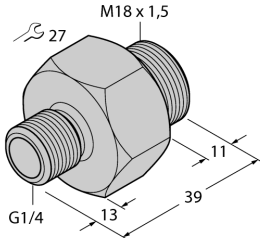
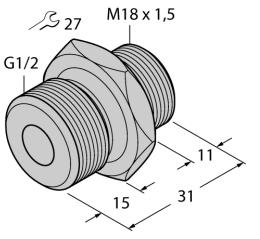
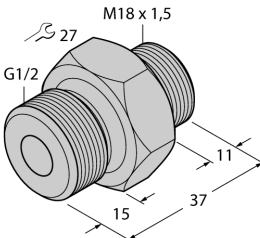
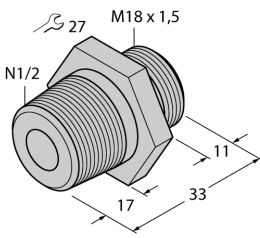
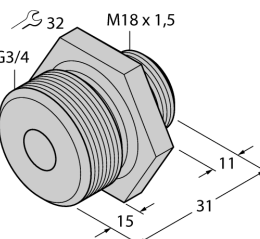
	<p>Optionally available: Screw-in adapter, stainless steel, M18 x 1.5 on G1/4 FCA-FCST-G1/4-A4 Ident-no. 6870290</p>	
	<p>Optionally available: Screw-in adapter, stainless steel, M18 x 1.5 on G1/2 FCA-FCST-G1/2-A4 Ident-no. 6870291</p>	
	<p>Optionally available: Screw-in adapter, stainless steel, M18 x 1.5 on G1/2 FCA-FCST-G1/2-A4/L037 Ident-no. 6870292</p>	
	<p>Optionally available: Screw-in adapter, stainless steel, M18 x 1.5 on G1/2 FCA-FCST-N1/2-A4 Ident-no. 6870293</p>	
	<p>Optionally available: Screw-in adapter, stainless steel, M18 x 1.5 on G3/4 FCA-FCST-G3/4-A4 Ident-no. 6870294</p>	

**Freely rotatable FCST flow sensor
monitoring of flow velocity
relay output 24 VDC NO
FCST-A4P-ARX-H1140**

LED display

LED	Color	Status	Description
LED 1	red	on	The flow has failed or dropped below the default setpoint. Switching output 1 is not switched.
LED 2	yellow	on	The setpoint is reached. Switching output 1 is switched.
LED 3 ... 6	green	on	The adjusted setpoint is exceeded. The number of illuminated LEDs is a measure of the relative exceedance of the setpoint. Switching output 1 is switched.

Mounting instructions

Mounting adapter	<p>The freely rotatable flow sensors are mounted with the FCA-FCST adapter. The adapter is screwed in a T-piece or a welding sleeve and sealed accordingly. When assembling adapters with cylindrical thread, use the enclosed seal (e.g. G1/4, G1/2, G3/4, etc.). Mounting adapters with NPT-thread are generally delivered without seal (e.g. N1/2). Use hemp or teflon tape</p> <p>The sensor is fixed in the adapter by means of a captive nut fitted between the upper housing part and the cone seat.</p>
Mounting position	<p>In order to minimize potential misinterpretations due to disturbance, it is recommended to position the sensor with a minimum separation distance of 3 x di before and 5 x di after bends, changes in cross section, valves, etc..</p> <ul style="list-style-type: none"> ■ If the flow channel is not completely filled with the medium, it is recommended to install the sensor from underneath. ■ If deposits are likely to built up, it is recommended to install the sensor on the side. It is important to note that deposits can also form on the tip, which may affect the monitoring results. Therefore, it is recommended to clean the sensor at regular intervals and to select the associated service interval accordingly. ■ If blistering is to be expected, ensure that there is no air bubble located in the area of the tip when installing the sensor. ■ If the sensor is mounted in vertical piping systems, it is recommended to position the sensor within the riser.
Correct installation	<p>To retrieve the full performance potential of the sensor, it must be aligned correctly. In particular when monitoring bad heat-conductive media such as oils, liquids with high solids, abrasive media, etc., when exposed to fast temperature changes (K/min) and, in general, near components with analog output.</p> <p>Correct installation is ensured, as soon as the effective flow direction of the application matches the direction of flow indicated by the "arrow" on the sensor.</p>

Adjustment guidelines

Switching outputs	Setup with resting medium	<ul style="list-style-type: none"> ■ Install sensor in the flow channel, switch on the device and wait for standby time. ■ Set the potentiometer S1 so that the red LED just turns on. In the case of two switching outputs also valid for S2. ■ When the medium starts to flow, at least one green LED should be on.
	Setup with flowing medium	<ul style="list-style-type: none"> ■ Install sensor in the flow channel, set flow and turn on the device. Wait for standby time. ■ Set potentiometer S1 so that one or two green LEDs are on. In the case of two switching outputs also valid for S2. ■ When the medium stops flowing, the red LED must turn on.